

Main Components

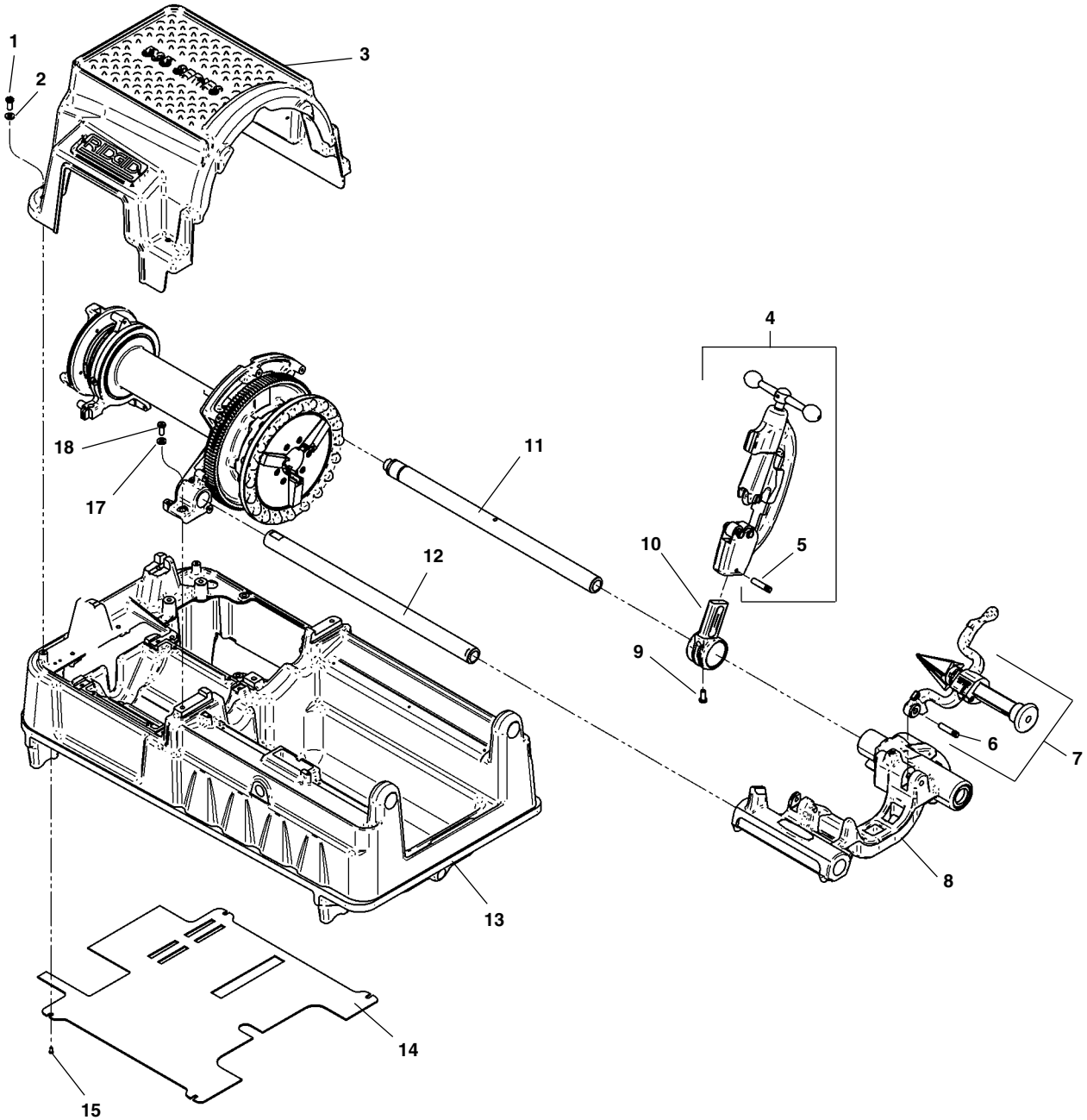

**NOTE: Order parts by Catalog Number only.  
DO NOT order by Reference Number.**

Ref. No.	Catalog No.	Description	Ref. No.	Catalog No.	Description
1	94332	Screw, Button Head 1/4" - 20 x 3/4" (4)	9	44930	Stop Screw
2	94322	Washer, Flat 1/4" (4)"	10	43690	Cutter Arm
3	94432	Top Cover	11	45220	Rear Support Bar
4	42390	820 Cutter Assembly	12	45440	Front Support Bar
5	47135	Stop Pin	13	94042	Base
6	47065	Pin	14	96432	Bottom Cover
7	42365	341 Reamer Assembly	15	94312	Screw, Pan Head #6 - 32 x 2" (4)
8	94357	Carriage Assembly			

### Drive Shaft Assembly

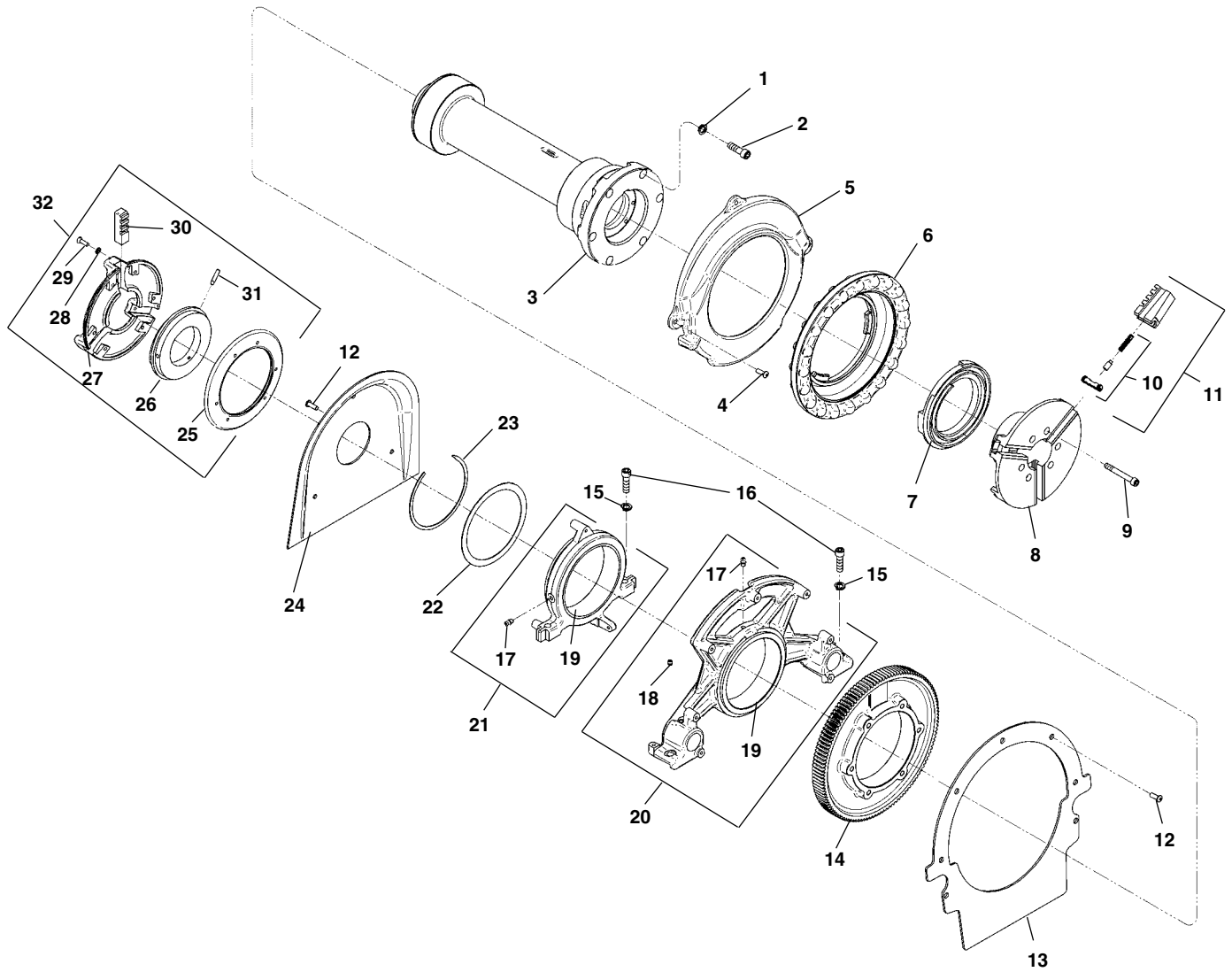

**NOTE: Order parts by Catalog Number only.  
DO NOT order by Reference Number.**

Ref. No.	Catalog No.	Description	Ref. No.	Catalog No.	Description
1	40930	Washer, Lock $\frac{3}{8}$ "	18	40910	Set Screw $\frac{1}{4}$ " - 20 x $\frac{3}{4}$ " (4)
2	46475	Screw, Soc. Hd. $\frac{3}{8}$ " - 16 x $1\frac{1}{4}$ "	19	93957	Spindle Bearing (2)
3	96427	Drive Shaft	20	94027	Front Bracket Assembly
4	94332	Screw, Button Head $\frac{1}{4}$ " - 20 x $\frac{3}{4}$ " (9)	21	94037	Rear Bracket Assembly
5	96407	Front Cover	22	94392	Thrust Washer
6	96422	Handwheel	23	94397	Retaining Ring
7	43450	Scroll	24	96487	Rear Cover
8	43525	Chuck Cap	25	43740	Back Plate
9	45295	Screw, $\frac{5}{16}$ " - 18 x $2\frac{3}{4}$ " (6)		19356	Back Plate - Europe
10	44715	Insert Set	26	44095	Scroll
11	44090	Front Jaw (4)	27	43735	Centering Head
12	94337	Screw, Button Head $\frac{1}{4}$ " - 20 x $\frac{3}{8}$ " (7)		19346	Centering Head - Europe
13	94072	Front Plate	28	40270	Lock Washer (6)
14	96417	Drive Gear	29	46790	Screw, #12-24 x $\frac{3}{4}$ " (6)
15	40930	Washer, Lock $\frac{3}{8}$ " (4)	30	46500	Centering Jaw (3)
16	46745	Screw, $\frac{3}{8}$ " - 16 x $1\frac{1}{4}$ " (4)	31	45260	Step Pin (3)
17	46860	Grease Fitting (2)	32	44165	Centering Head Assembly

**1101**  
**2301**

## Motor

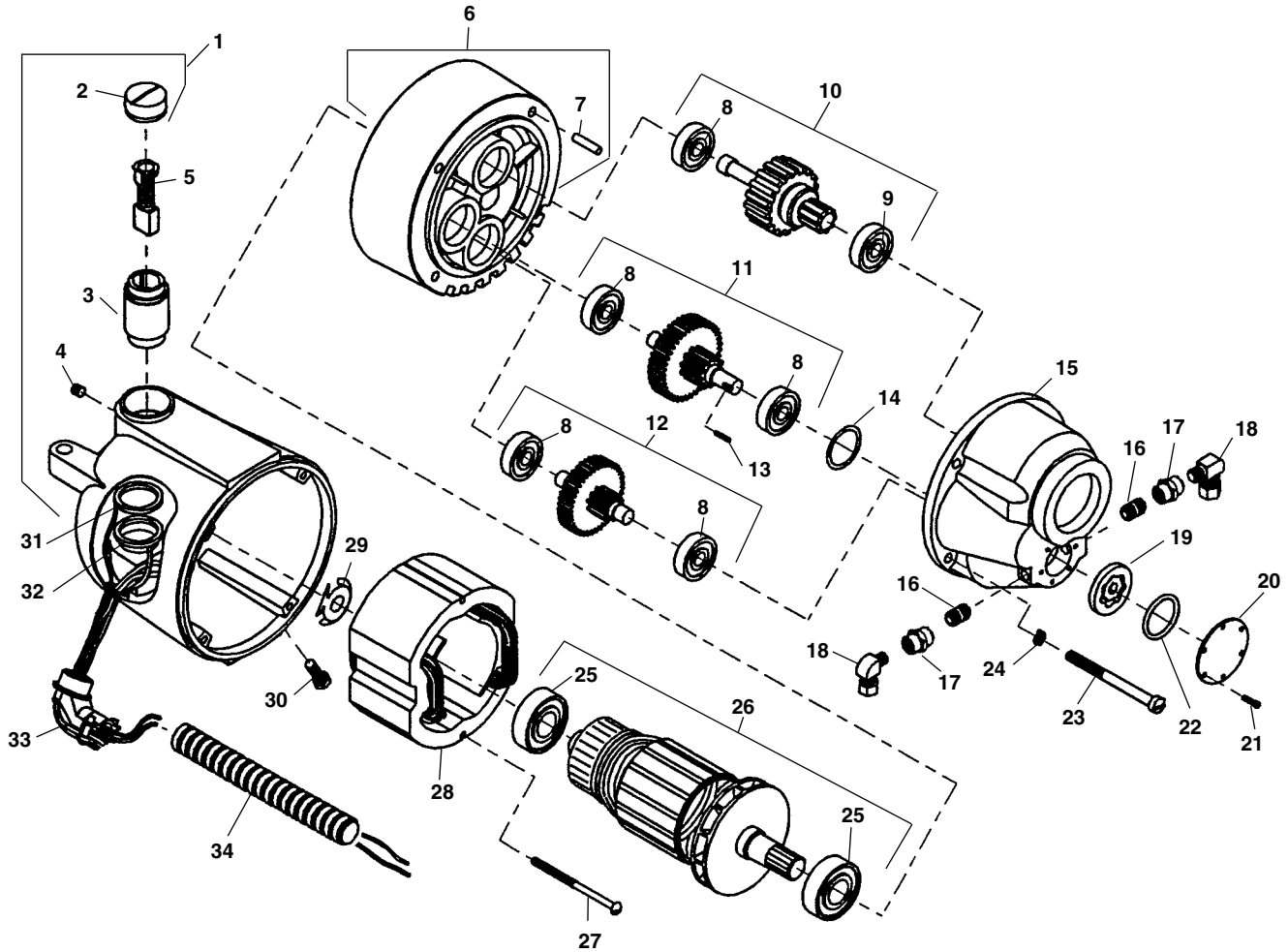

**NOTE: Order parts by Catalog Number only.  
DO NOT order by Reference Number.**

Ref. No.	Catalog No.	Description	Ref. No.	Catalog No.	Description	Ref. No.	Catalog No.	Description
—	96442	1101 Motor 115V	12	52527	2nd Gear Assembly	25	52517	Male Elbow
—	21208	2301 Motor 230V	13	96885	Pin	26	44565	Armature Bearing (2)
1	43160	Housing Assembly	14	96880	Oil Seal	27	52497	Armature (115V)
2	44545	Brush Cap Set	15	96830	Gear Housing		52492	Armature (230V)
3	45025	Brush Holder Set	16	52507	Pipe Nipple 1/8" NPT (2)	27	44555	Mounting Screw (2)
4	39770	Set Screw (2)	17	52512	Coupling 1/8" NPT (2)	28	44015	Field (115V)
5	44540	Brush Assembly Set	18	52517	90° Elbow Fitting (2)		44035	Field (230V)
6	54552	Fan Housing Assembly	19	96870	Gerotor Set	29	44580	Loading Spring
7	45165	Dowel Pin	20	96840	Cover Plate	30	83500	Locking Screw (2)
8	45060	Gear Bearings (5)	21	96890	Screw (6)	31	96942	White Upper Lead
9	45315	Front Bearing	22	96875	O Ring	32	96492	Red Lower lead
10	96437	Drive Gear	23	45075	Screw (4)	33	46900	Connector 90
11	52522	1st Gear Assembly	24	45150	Lock Washer	34	96482	Flexible Conduit

**Oiling Components**

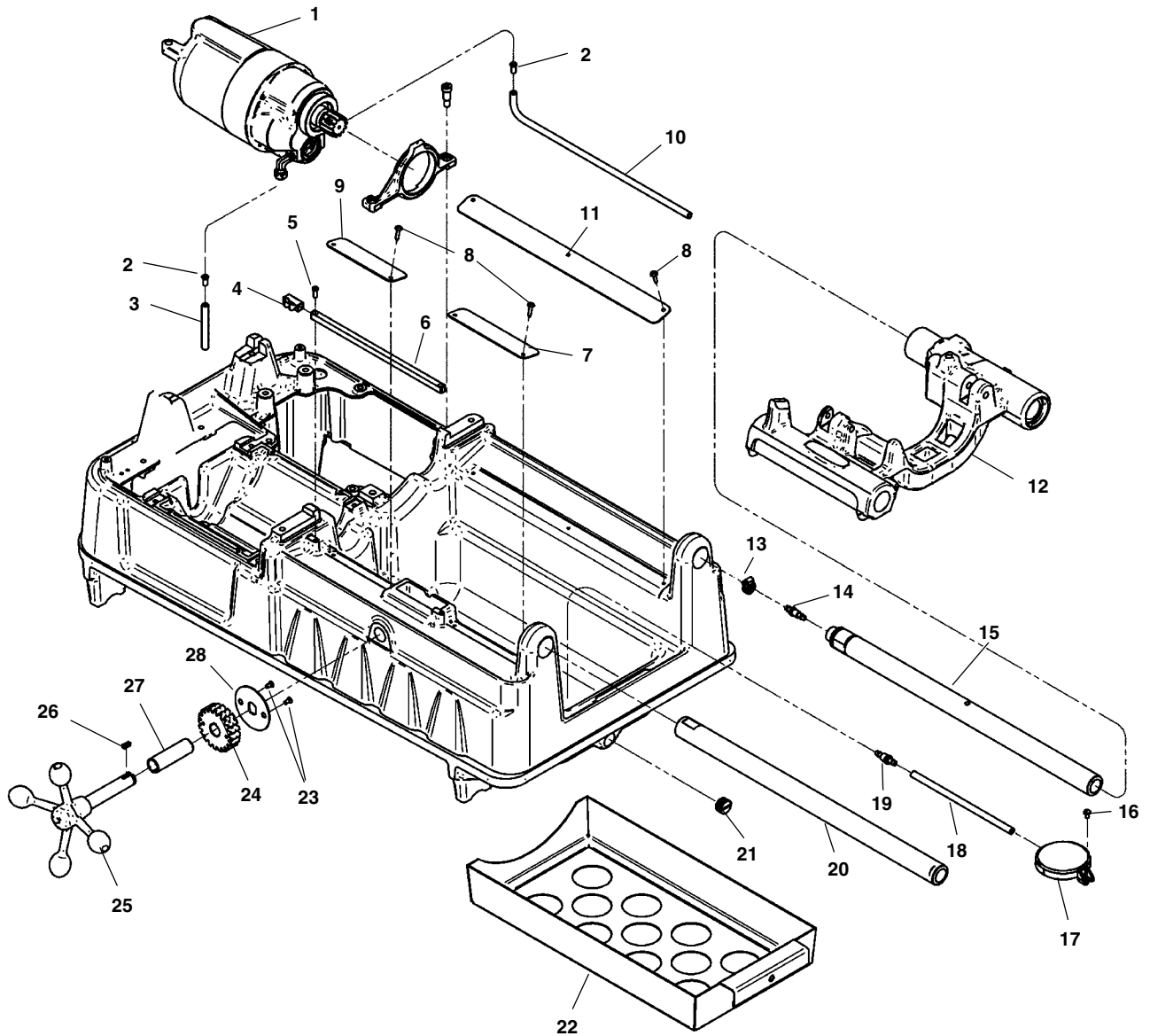

**NOTE: Order parts by Catalog Number only.  
DO NOT order by Reference Number.**

Ref. No.	Catalog No.	Description	Ref. No.	Catalog No.	Description
1	96442	1101 Motor Assembly 115V	15	45220	Support Bar, Rear
	21208	2301 Motor Assembly 230V	16	45420	Screw, #10 - 32 x 3/8"
2	35117	Tube Insert	17	58467	Filter Screen Assembly
3	96477	Oil Hose, Input 13"	18	87950	Oil Hose, Filter
4	47110	Indicator Slide	19	54142	Bulkhead Fitting
5	45615	Screw, Flat Head #10 - 32 x 1/2" (2)	20	45440	Support Bar, Front
6	47105	Length Indicator Bar	21	96447	Drain Plug 1/2" NPT
7	94117	Drip Edge	22	94112	Chip Tray
8	43367	Screw, #8 x 3/4"	23	46785	Screw, Flat Head #10 - 32 x 3/8" (2)
9	94122	Drip Edge	24	45430	Pinion
10	58482	Oil Hose, Input 25"	25	94012	Handwheel
11	94127	Drip Edge	26	94267	Key, 3/16" Square x 1/2"
12	94357	Carriage Assembly	27	94222	Bushing
13	35142	Hose Clamp	28	47120	Pinion Lock Ring
14	69167	Barbed Fitting			

Electrical Components

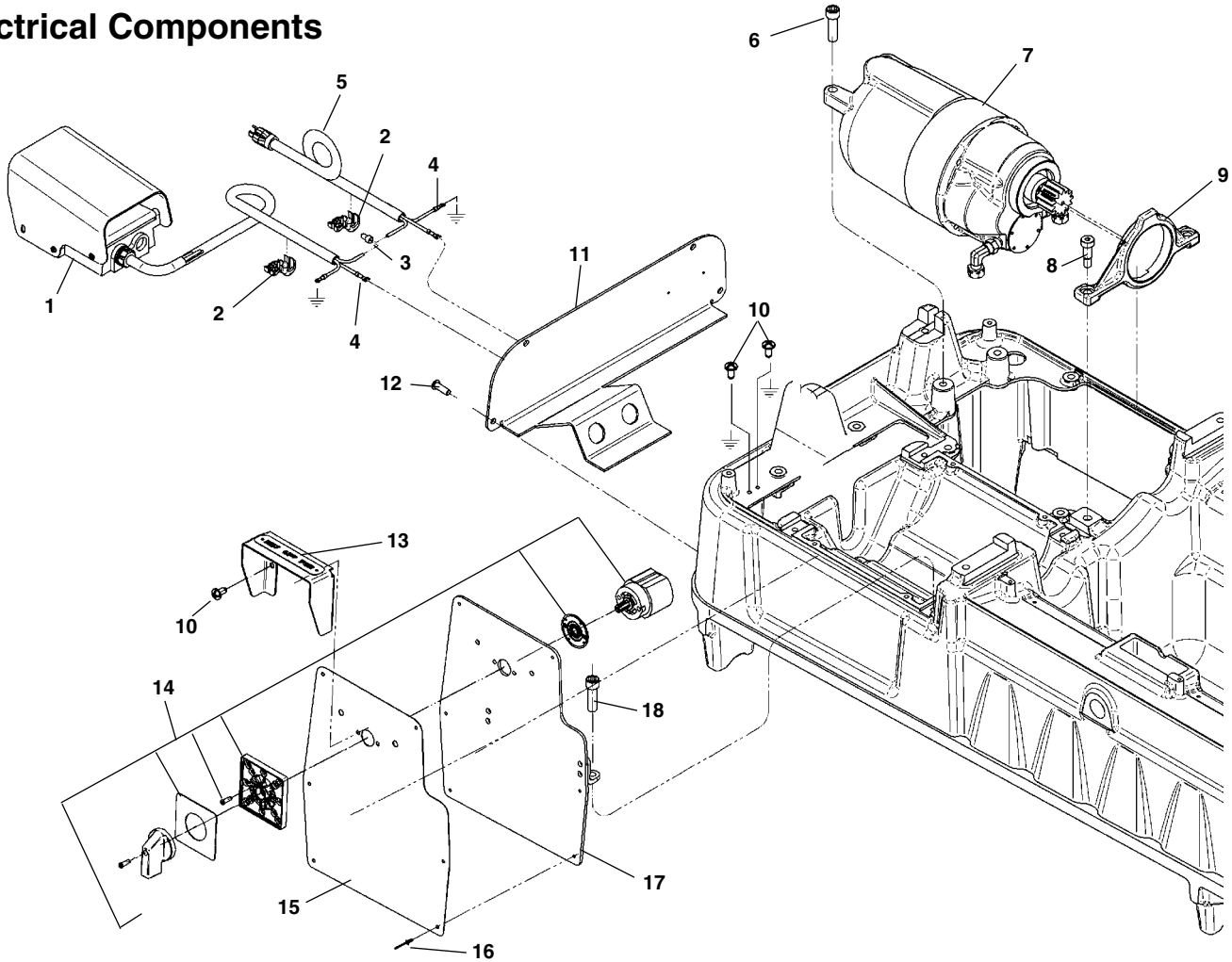

**NOTE: Order parts by Catalog Number only.  
DO NOT order by Reference Number.**

Ref. No.	Catalog No.	Description	Ref. No.	Catalog No.	Description
1	36642	Foot Switch, B-294	11	94152	Back Cover
2	75952	Strain Relief (2)	12	94337	Screw, Button Head 1/4" x 20 x 3/8" B.H.C.S. (4)
3	44635	End Splice	13	96452	Switch Cover
4	46875	Spade Terminal (2)	14	20123	Switch Assembly
5	75902	Power Cord 115V	15	96472	Warning Label
6	46745	Screw (2)	16	94427	Pop Rivet (6)
7	96442	Motor	17	96457	Control Panel
8	36262	Shoulder Bolt (2)	18	40910	Screw
9	96402	Motor Bracket			
10	45420	Screw (4)			

Wiring Diagram

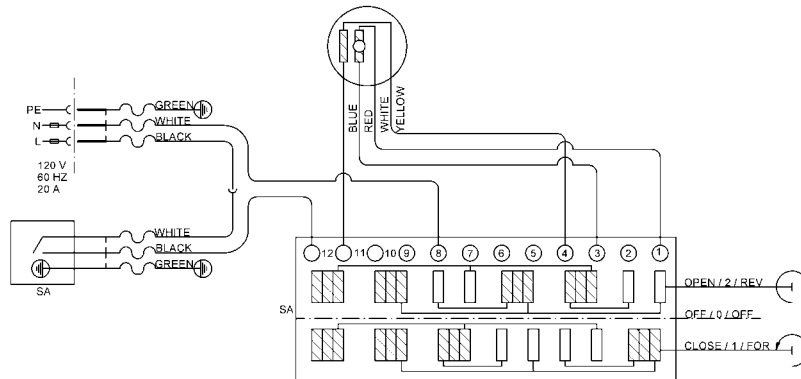

**Carriage**

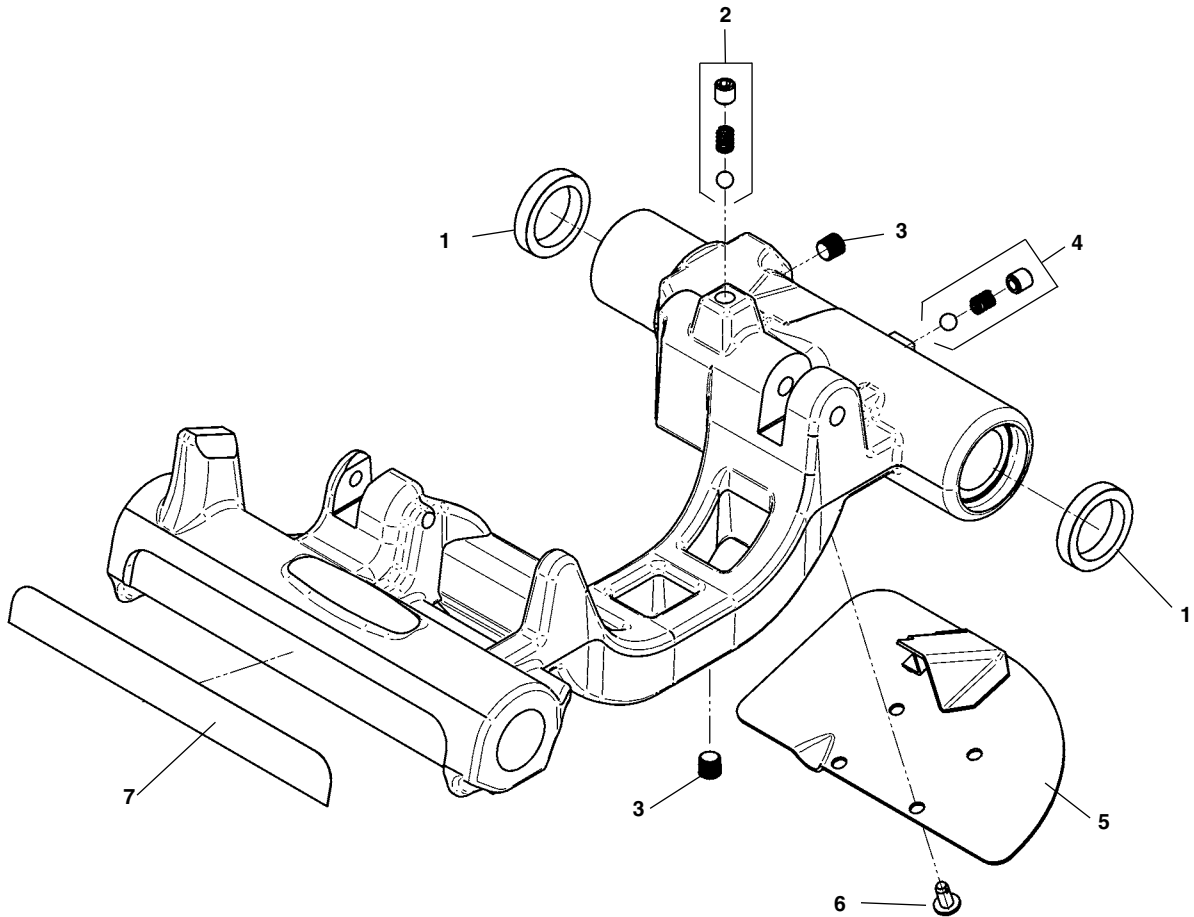

**NOTE: Order parts by Catalog Number only.  
DO NOT order by Reference Number.**

Ref. No.	Catalog No.	Description
—	94357	Carriage Assembly
1	46720	Oil Seal
2	46810	Die Head Dètente
3	46815	Pipe Plug, 1/8" NPT (2)
4	35307	Pressure Relief Set
5	45195	Drip Tray
6	46270	Screw, 1/4" - 20 x 1/2" (4)
7	46370	Length Gauge

No. 341 Reamer

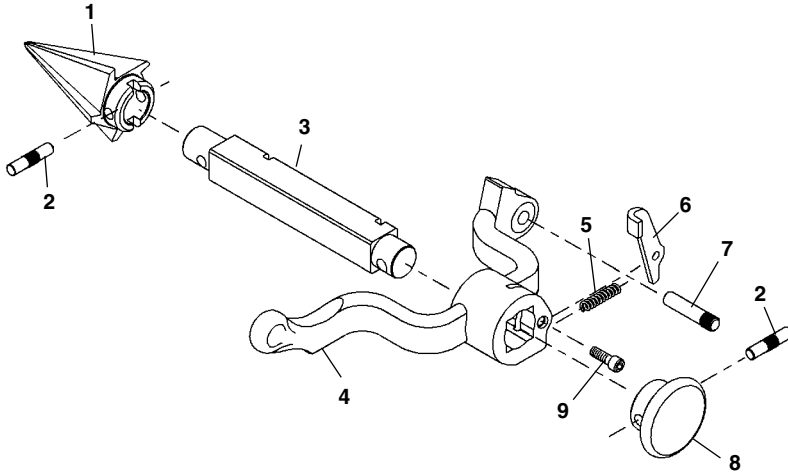

**NOTE: Order parts by Catalog Number only.  
DO NOT order by Reference Number.**

Ref. No.	Catalog No.	Description
—	42365	341 Reamer Complete
1	36277	Cone (R.H.)
	46660	Cone (L.H. & R.H.)
2	47155	Pin
3	43790	Reamer Bar
4	43230	Reamer Arm
5	44700	Latch Spring
6	46665	Reamer Latch
7	47065	Hinge Pin
8	46585	Reamer Knob
9	46515	Screw 1/4" - 20 x 3/4"

No. 820 Cutter

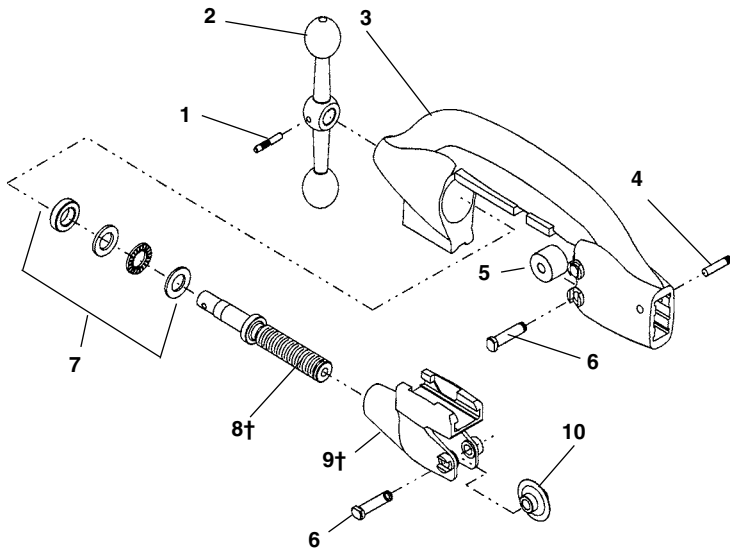

Ref. No.	Catalog No.	Description
—	42390	820 Cutter Complete
1	47160	Crank Pin
2	45765	Feed Screw Crank
3	43040	Cutter Frame
4	47135	Stop Pin
5	34775	Cutter Roll (2)
6	34780	Cutter & Roll Pin (3)
7	46725	Thrust Bearing Assembly
8†	45780	Feed Screw
9†	43245	Wheel Housing
10	44185	Cutter Wheel
	44190	Cutter Wheel f/Stainless

† Service Note: When replacing parts on early style (fine thread) cutters, both feed screw and wheel housing must be replaced.