

**RYOBI 10 in. (254 mm)
MITER SAW**

MODEL NO. TS1302

REPAIR SHEET

FIGURE A

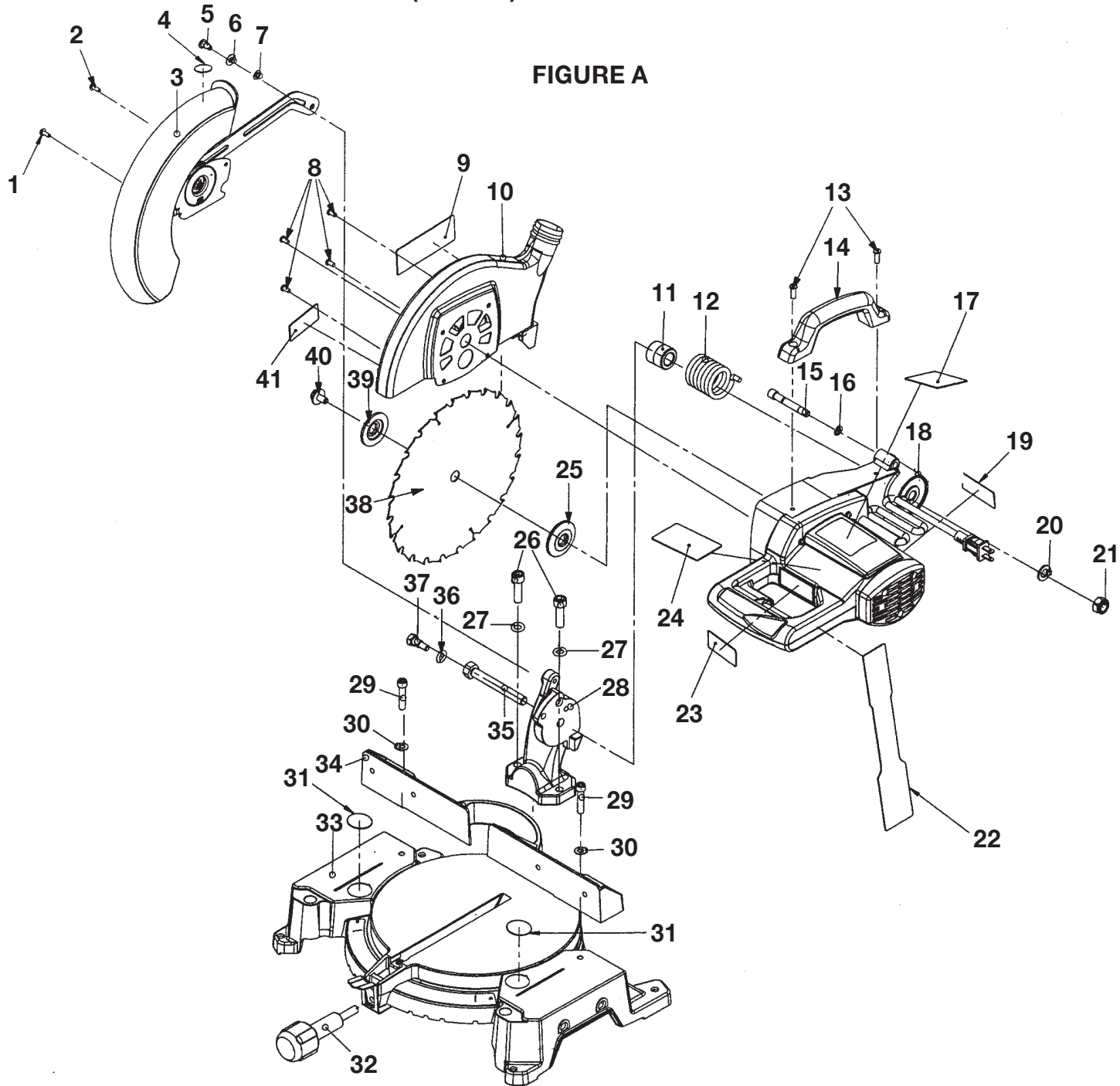

RYOBI 10 in. (254 mm) MITER SAW – MODEL NO. TS1302

The model number will be found on a plate attached to the motor housing. Always mention the model number in all correspondence regarding your **Miter Saw** or when ordering repair parts.

PARTS LIST FOR FIGURE A

Key No.	Part Number	Description	Qty.	Key No.	Part Number	Description	Qty.
1	020123-004	* SCREW (10-32 X 5.5L)	1	22	867217-007	HANDLE WARNING LABEL	1
2	020123-006	* SCREW (10-32 X 5/16L)	1	23	867217-003	LOGO PLATE (MOTOR)	1
3	900845-000	LOWER GUARD ASSEMBLY (SEE FIGURE B)		24	867117-002	FR./SP. WARNING LABEL	1
4	867107-013	LOWER GUARD WARNING LABEL	1	25	270511-000	BLADE COLLAR (INNER)	1
5	020113-008	* SCREW SHOULDER (M6 X 10L)	1	26	020615-003	SCREW	2
6	021403-007	* WAVE WASHER (7.5 X 12.7 X 0.4T)	1	27	021205-001	SPRING WASHER (M10)	2
7	021103-010	* WASHER (7.5 X 16 X 0.8T)	1	28	225240-000	PIVOT	1
8	020704-012	* SCREW W/WASHER (M5 X 15 mm)	4	29	020606-009	* SCREW (5/16-18 X 1-1/2 in.)	2
9	867107-010	RYOBI LOGO PLATE	1	30	021120-003	* WASHER (8 X 16 X 1.2T)	2
10	900844-000	UPPER GUARD ASSEMBLY	1	31	867227-001	BASE – NO HANDS LABEL	2
11	303577-000	SLEEVE	1	32	900786-001	MITER HANDLE	1
12	029231-001	TORSION SPRING	1	33	900875-000	TABLE & BASE ASSEMBLY (SEE FIGURE C)	
13	020102-005	* SCREW (M6 X 18 mm)	2	34	225242-000	FENCE	1
14	303507-000	HANDLE	1	35	028960-000	PIVOT BOLT	1
15	026308-001	LATCH PIN	1	36	021205-001	* WASHER (M10)	2
16	025100-001	"O" RING	1	37	020145-001	SCREW	1
17	867217-002	ENG. WARNING LABEL	1	38	350056-001	BLADE	1
18	990053-000	MOTOR ASSEMBLY (SEE FIGURE D)		39	270373-000	BLADE COLLAR (OUTER)	1
19	871053-000	DATA PLATE	1	40	020300-011	ARBOR SCREW	1
20	021117-003	* FLAT WASHER (12.2 X 22 X 2T)	1	41	867217-004	UPPER GUARD LABEL	1
21	022300-001	* NUT (M12 X 1.75P)	1				

* STANDARD HARDWARE ITEM – MAY BE PURCHASED LOCALLY

WARNING: Improper repair of a double insulated tool can result in damages to the double insulation system possibly causing electrical shock or electrocution. Any repairs requiring disassembly of your tool requires safety testing and should only be performed by a Ryobi Authorized Service Center. For the service center nearest you call 1-800-525-2579 in the United States or 1-866-897-9624 in Canada.

FIGURE B

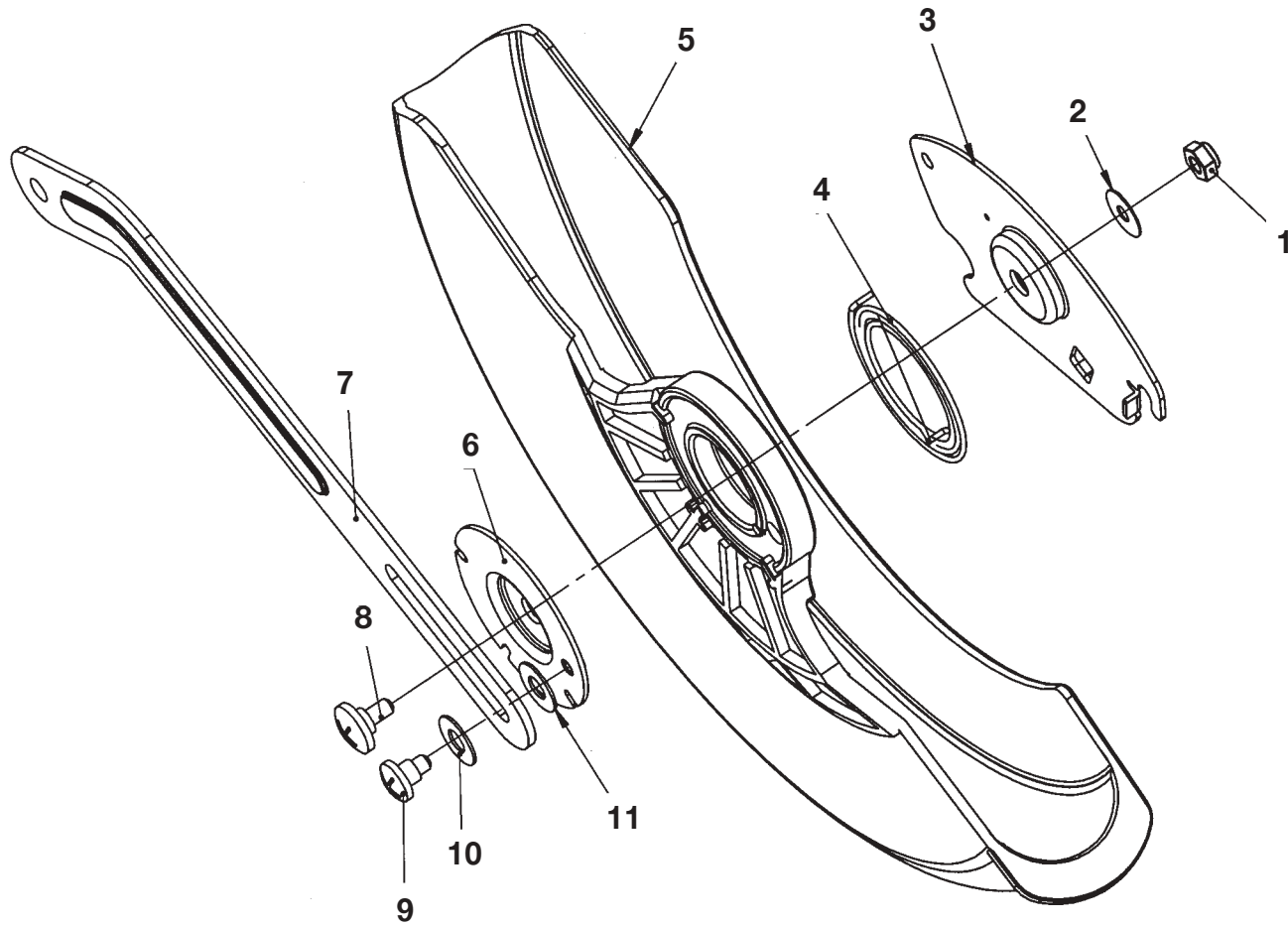

RYOBI 10 in. (254 mm) MITER SAW – MODEL NO. TS1302

The model number will be found on a plate attached to the motor housing. Always mention the model number in all correspondence regarding your **Miter Saw** or when ordering repair parts.

PARTS LIST FOR FIGURE B

Key No.	Part Number	Description	Qty.
1	022307-001	* NUT (10-32)	1
2	021108-006	* WASHER (13/64 X 15/32 X 0.5T)	1
3	270573-000	LOWER GUARD PLATE	1
4	029303-003	GUARD SPRING	1
5	303509-000	LOWER GUARD	1
6	270376-005	PLATE	1
7	270574-000	LEVER	1
8	028939-004	SCREW (10-32)	1
9	028931-002	* SCREW (M5 X 0.8P)	1
10	021103-010	* WASHER (7.5 X 16 X 0.8T)	1
11	021119-002	* WASHER (5.5 X 16 X 0.8T)	1
	983000-247	OPERATOR'S MANUAL	
	983000-247R	REPAIR SHEET (REV:02)	
	3-22-05		

*** STANDARD HARDWARE ITEM – MAY BE PURCHASED LOCALLY**

WARNING: Improper repair of a double insulated tool can result in damages to the double insulation system possibly causing electrical shock or electrocution. Any repairs requiring disassembly of your tool requires safety testing and should only be performed by a Ryobi Authorized Service Center. For the service center nearest you call 1-800-525-2579 in the United States or 1-866-897-9624 in Canada.

FIGURE C

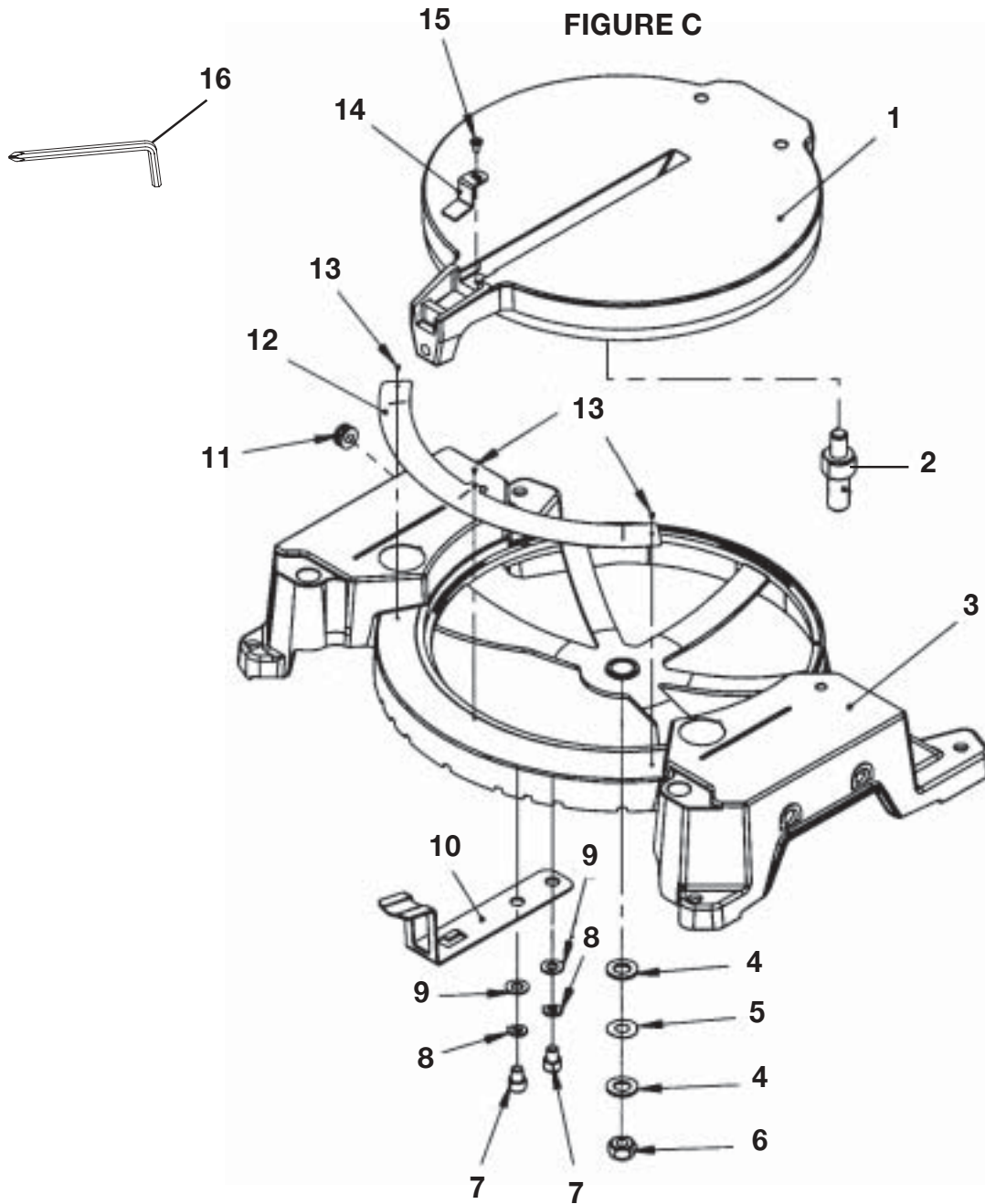

RYOBI 10 in. (254 mm) MITER SAW – MODEL NO. TS1302

The model number will be found on a plate attached to the motor housing. Always mention the model number in all correspondence regarding your **Miter Saw** or when ordering repair parts.

PARTS LIST FOR FIGURE C

Key No.	Part Number	Description	Qty.
1	225241-000	TABLE	1
2	028961-000	SHOULDER BOLT	1
3	225231-000	BASE	1
4	021109-011	* WASHER (0.505 in. X 13/16 in. X 1T)	2
5	021403-001	WAVE WASHER	1
6	022308-001	* NYLON NUT (M10 X 1.5P)	1
7	020606-013	HEX SOCKET BOLT	2
8	021204-001	WASHER	2
9	021120-001	* FLAT WASHER (8 X 14 X 2T)	2
10	270572-000	SPRING INDEX	1
11	330030-000	GROMMET	1
12	870028-001	MITER SCALE	1
13	024400-000	COACH SCREW	3
14	303508-000	MITER POINTER	1
15	020726-003	* SCREW W/WASHER (M10 X 35 mm)	1
16	040027-000	BLADE WRENCH (1/4 in. X 100 mm)	2

*** STANDARD HARDWARE ITEM – MAY BE PURCHASED LOCALLY**

WARNING: Improper repair of a double insulated tool can result in damages to the double insulation system possibly causing electrical shock or electrocution. Any repairs requiring disassembly of your tool requires safety testing and should only be performed by a Ryobi Authorized Service Center. For the service center nearest you call 1-800-525-2579 in the United States or 1-866-897-9624 in Canada.

FIGURE D

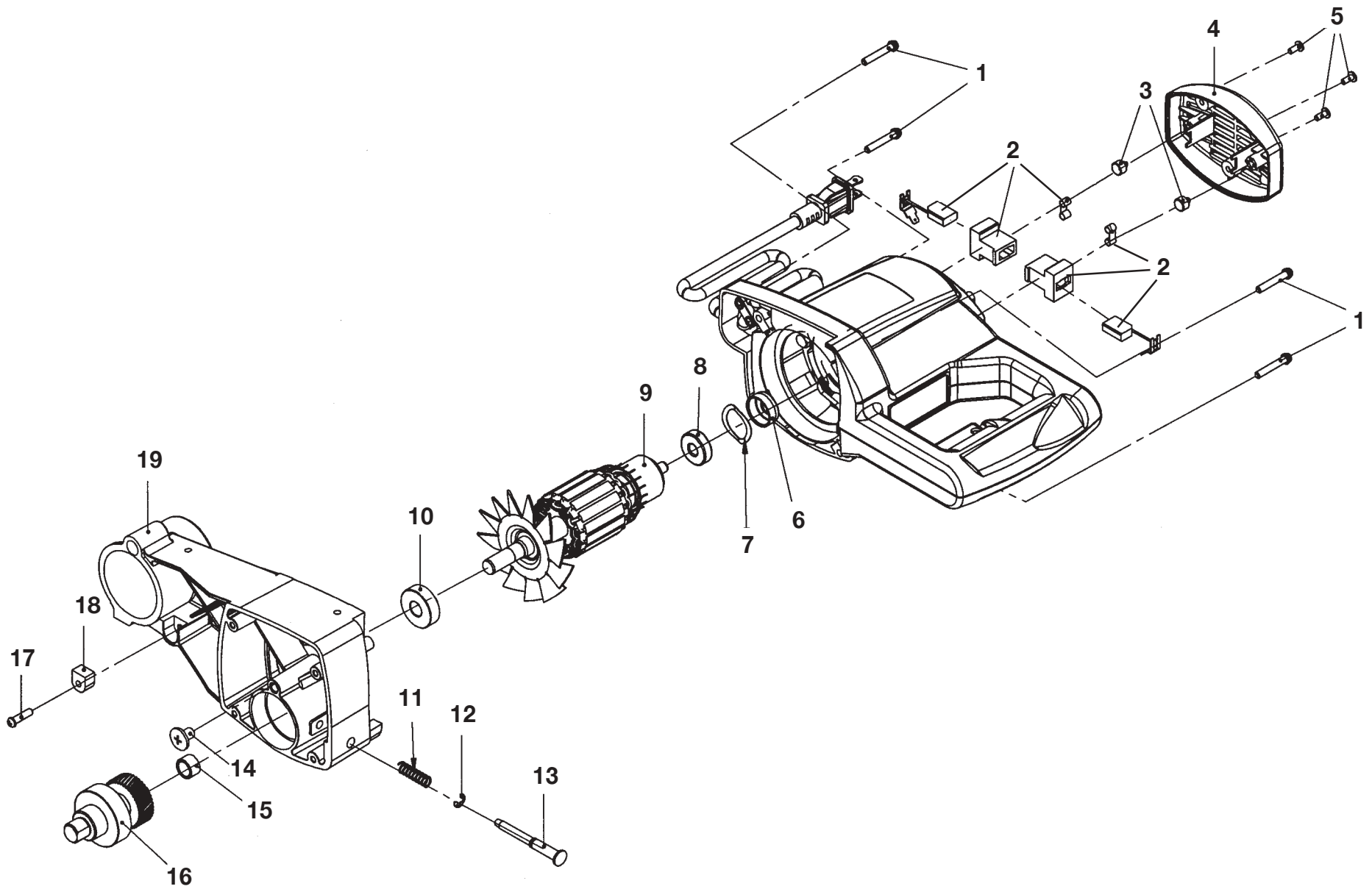

RYOBI 10 in. (254 mm) MITER SAW – MODEL NO. TS1302

The model number will be found on a plate attached to the motor housing. Always mention the model number in all correspondence regarding your **Miter Saw** or when ordering repair parts.

PARTS LIST FOR FIGURE D

Key No.	Part Number	Description	Qty.
1	020703-009	* SCREW W/WASHER (M5 X 0.8 X 32L)	4
2	984799-001	CARBON BRUSH ASSEMBLY	2
3	303085-000	BRUSH HOLDER CAP	2
4	303575-000	MOTOR END CAP	1
5	020132-001	* SCREW (M4 X 0.7 X 10L)	3
6	330052-000	BEARING COVER	1
7	021400-001	* WASHER (20.0 X 14.5 X 0.3T)	1
8	050007-000	BEARING (608LZ)	1
9	984798-001	ARMATURE ASSEMBLY	1
10	050010-100	BEARING (6201LLU)	1
11	029151-001	SPRING	1
12	023206-001	RETAINING RING	1
13	290113-001	ARBOR LOCK	1
14	028930-003	SCREW W/WASHER	1
15	052001-000	NEEDLE BEARING	1
16	984796-001	OUTPUT SPINDLE/GEAR ASSEMBLY	1
17	020106-009	* SCREW (M5 X 20 mm)	1
18	303024-000	BUMPER	1
19	984797-001	GEAR HOUSING ASSEMBLY (INCLUDES KEY NO. 15)	1

WARNING: Improper repair of a double insulated tool can result in damages to the double insulation system possibly causing electrical shock or electrocution. Any repairs requiring disassembly of your tool requires safety testing and should only be performed by a Ryobi Authorized Service Center. For the service center nearest you call 1-800-525-2579 in the United States or 1-866-897-9624 in Canada.

FIGURE E

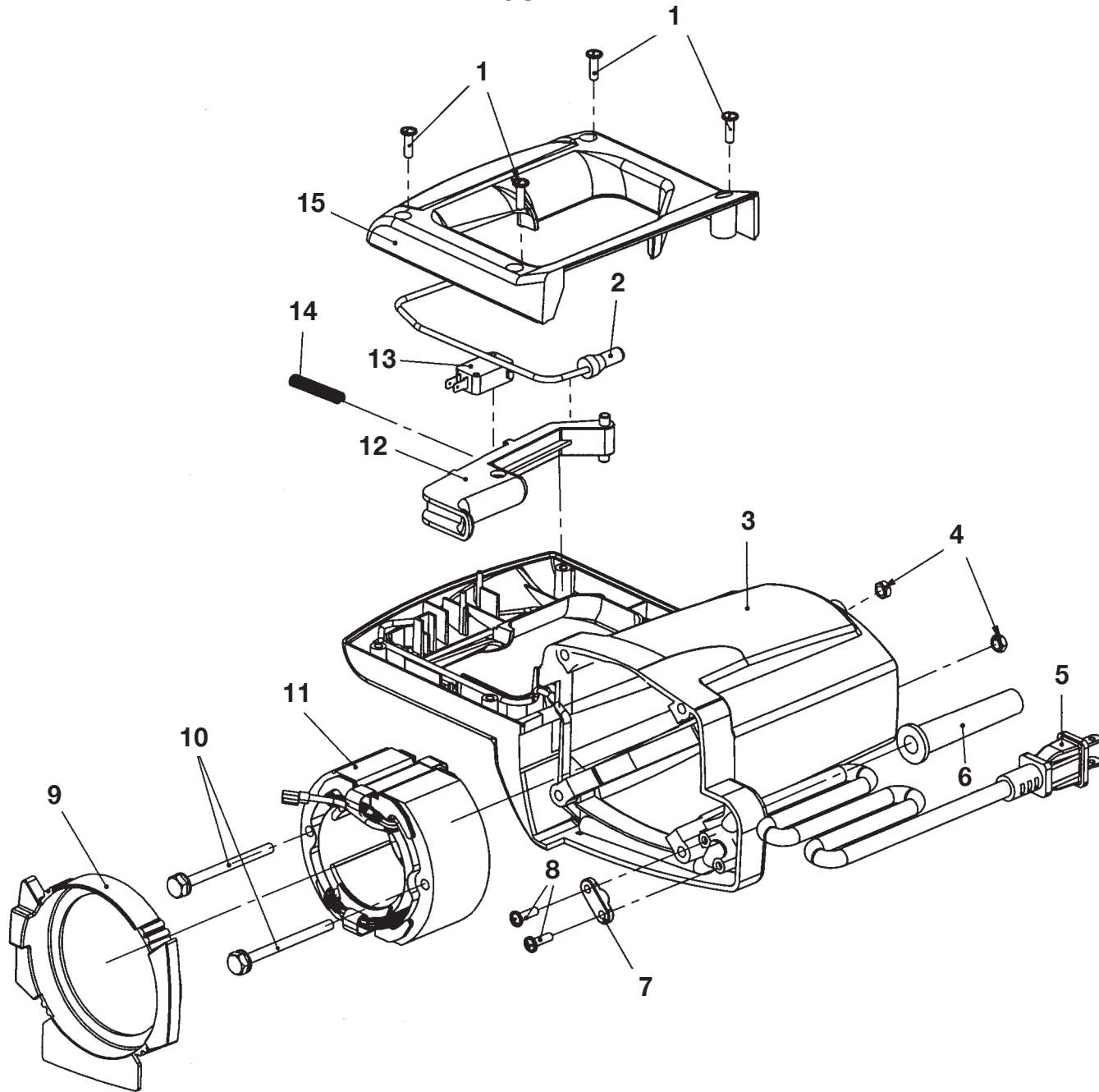

RYOBI 10 in. (254 mm) MITER SAW – MODEL NO. TS1302

The model number will be found on a plate attached to the motor housing. Always mention the model number in all correspondence regarding your **Miter Saw** or when ordering repair parts.

PARTS LIST FOR FIGURE E

Key No.	Part Number	Description	Qty.
1	020132-003	* SCREW W/WASHER (M4 X 0.7 X 14L)	4
2	364001-001	TERMINAL	1
3	303504-000	MOTOR HOUSING	1
4	022101-000	NUT (M5 X 0.8 mm)	2
5	900787-000	CORD W/PLUG	1
6	330021-000	CORD SLEEVE	1
7	303006-000	CORD CLAMP	1
8	020132-000	* SCREW (M4 X 0.7 X 14L)	2
9	303435-000	RING BAFFLE	1
10	028600-001	HEX BOLT (M5 X 65L)	2
11	170024-000	FIELD	1
12	303436-000	TRIGGER	1
13	303288-000	SWITCH	1
14	029166-001	SPRING	1
15	303431-000	LOWER HANDLE	1

*** STANDARD HARDWARE ITEM – MAY BE PURCHASED LOCALLY**

WARNING: Improper repair of a double insulated tool can result in damages to the double insulation system possibly causing electrical shock or electrocution. Any repairs requiring disassembly of your tool requires safety testing and should only be performed by a Ryobi Authorized Service Center. For the service center nearest you call 1-800-525-2579 in the United States or 1-866-897-9624 in Canada.

FIGURE F

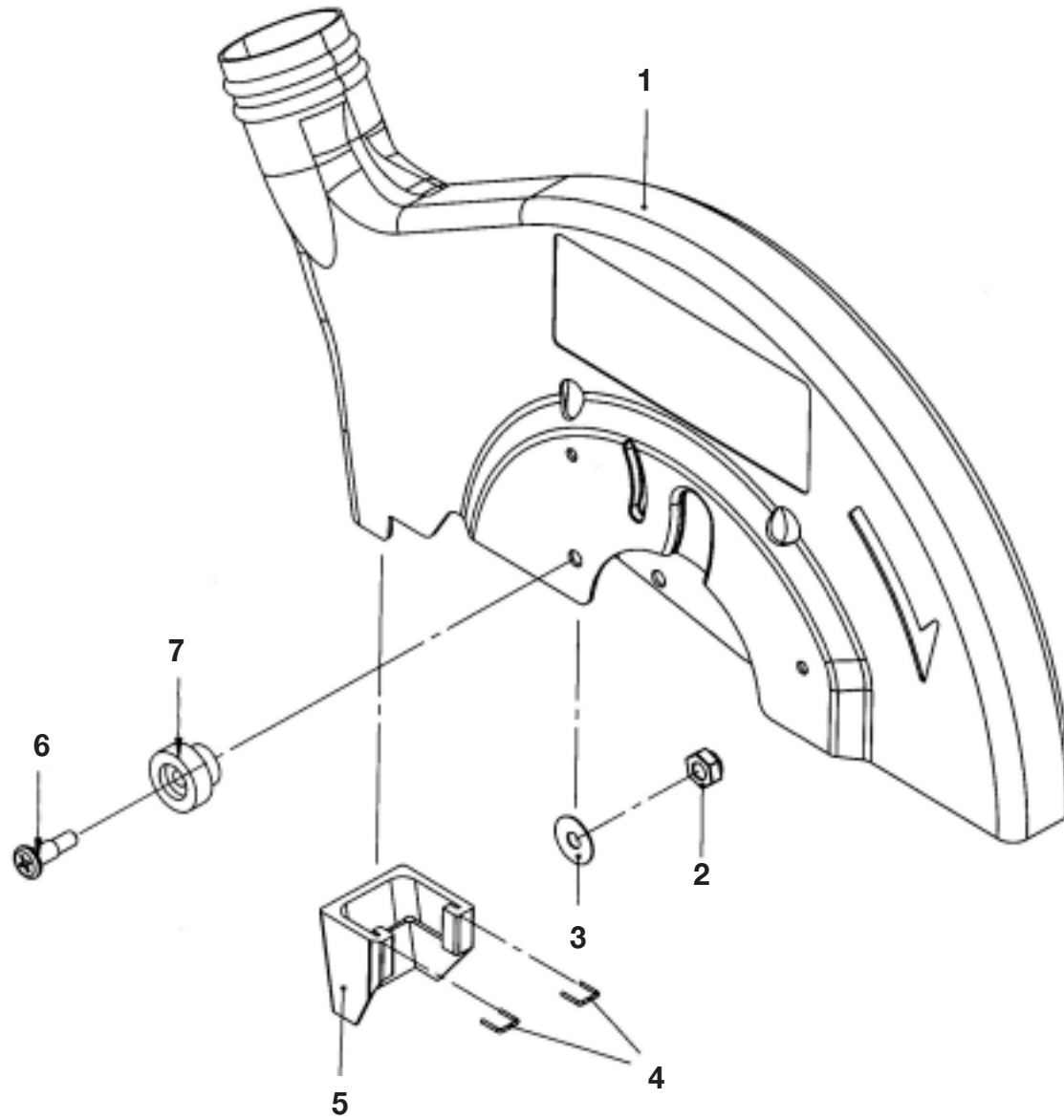

RYOBI 10 in. (254 mm) MITER SAW – MODEL NO. TS1302

The model number will be found on a plate attached to the motor housing. Always mention the model number in all correspondence regarding your **Miter Saw** or when ordering repair parts.

PARTS LIST FOR FIGURE F

Key No.	Part Number	Description	Qty.
1	290205-000	UPPER BLADE GUARD	1
2	022307-001	NYLON NUT	1
3	021108-006	WASHER	1
4	029719-001	SPRING	2
5	330055-000	DUST COLLECTOR	1
6	028921-003	SPRING SCREW	1
7	330027-000	RUBBER SLEEVE	1

*** STANDARD HARDWARE ITEM – MAY BE PURCHASED LOCALLY**

WARNING: Improper repair of a double insulated tool can result in damages to the double insulation system possibly causing electrical shock or electrocution. Any repairs requiring disassembly of your tool requires safety testing and should only be performed by a Ryobi Authorized Service Center. For the service center nearest you call 1-800-525-2579 in the United States or 1-866-897-9624 in Canada.

RYOBI 10 in. (254 mm) MITER SAW – MODEL NO. TS1302

The model number will be found on a plate attached to the motor housing. Always mention the model number in all correspondence regarding your **Miter Saw** or when ordering repair parts.

PARTS LIST FOR ACCESSORIES

Key No.	Part Number	Description	Qty.
1	330019-000	DUST GUIDE	1
2	900324-006	DUST BAG ASSEMBLY	1
3	900263-000	TABLE EXTENSION ASSEMBLY	2
4	900266-000	CLAMP BRACKET ASSEMBLY	2
5	900757-000	STOP BLOCK ASSEMBLY	1
6	020402-002	WING SCREW	1
7	900786-001	MITER LOCK HANDLE	1
8	900239-000	WORK CLAMP	1

NOTE: The above Accessories are not shown on the Repair Sheet.

WARNING: Improper repair of a double insulated tool can result in damages to the double insulation system possibly causing electrical shock or electrocution. Any repairs requiring disassembly of your tool requires safety testing and should only be performed by a Ryobi Authorized Service Center. For the service center nearest you call 1-800-525-2579 in the United States or 1-866-897-9624 in Canada.