

**RYOBI**

**16 in. (406 mm) SCROLL SAW**

**MODEL NO. SC164VS**

**REPAIR SHEET**

# RYOBI 16 in. (406 mm) SCROLL SAW – MODEL SC164VS

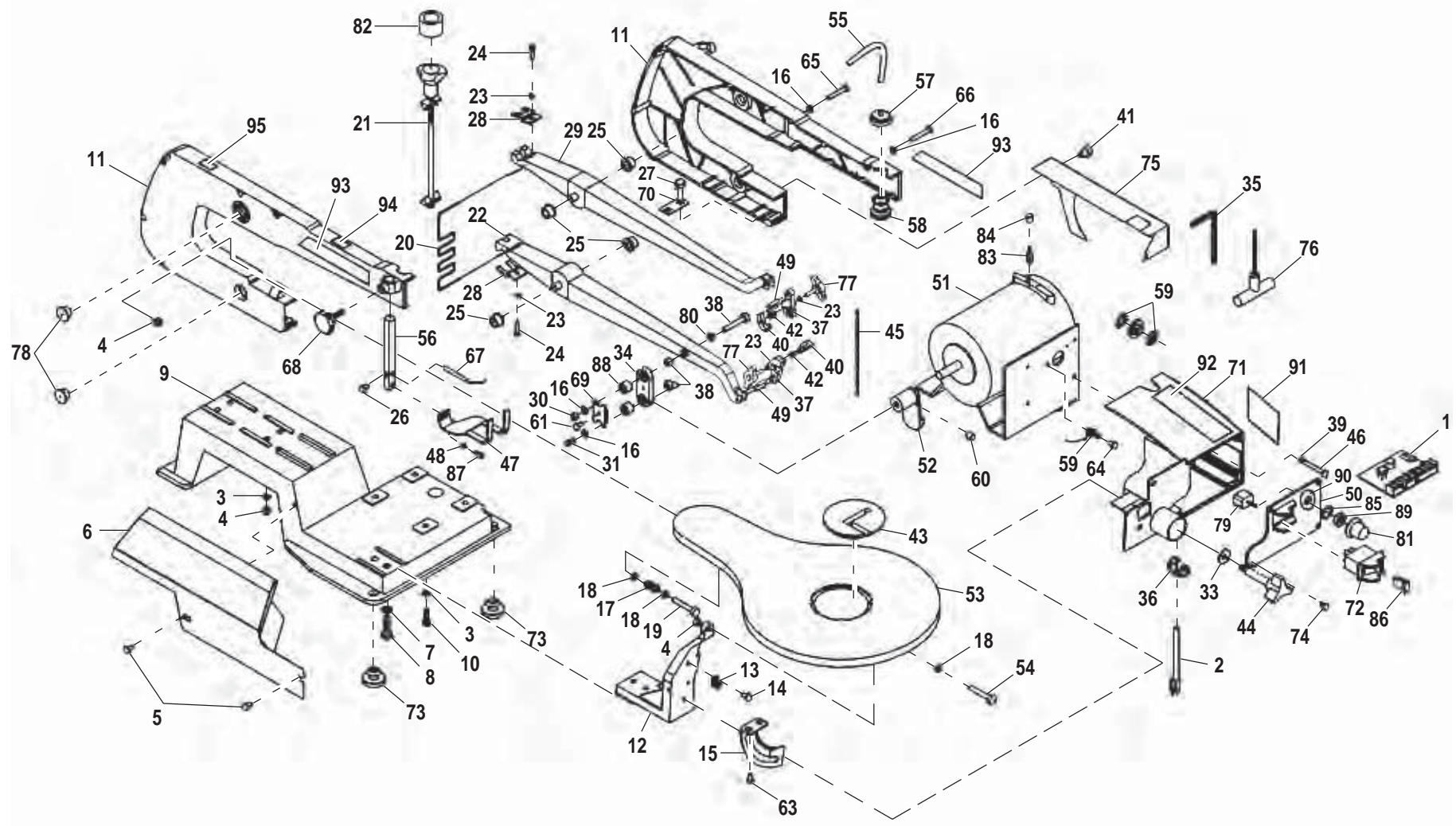

## RYOBI 16 in. (406 mm) SCROLL SAW – MODEL SC164VS

The model number will be found on a plate attached to the motor housing. Always mention the model number in all correspondence regarding your **Scroll Saw** or when ordering repair parts.

### PARTS LIST

Key No.	Part Number	Description	Qty.	Key No.	Part Number	Description	Qty.
1	S1605007	CIRCUIT BOARD .....	1	24	TSC07002	* SCREW (M4 X 10 mm) .....	2
2	S1605004A	POWER CORD .....	1	25	S1601003	OIL BUSHING .....	4
3	TSC11007	* SPRING WASHER (M6) .....	8	26	TSC07010	* SCREW (M5 X 6 mm) .....	1
4	TSC06001	* HEX NUT (M6) .....	6	27	TSC13001	* CARRIAGE BOLT (M6 X 25 mm) .....	4
5	TSC07008	* SCREW (M5 X 10 mm) .....	5	28	S1604004	RETAINER .....	2
6	S1601009F	COVER PLATE .....	1	29	S1602001B1	UPPER ARM .....	1
7	TSC11003	* SPRING WASHER (M8) .....	2	30	TSC06002	* HEX NUT (M5) .....	1
8	TSC05001	* BOLT (M8 X 25 mm) .....	2	31	TSC07003	* SCREW (M5 X 20 mm) .....	1
9	S1601004C	BASE .....	1	32	S1602003	SPACER .....	2
10	TSC05002	* BOLT (M6 X 16 mm) .....	4	33	TSC11006	* LARGE WASHER (M6) .....	1
11	S1601001	HOUSING ASSEMBLY .....	1	34	S16020021	LINK ASSEMBLY .....	1
12	S1601006C	TABLE SUPPORT .....	1	35	TSC04001	* HEX KEY (M4) .....	1
13	S1601012	SCALE INDICATOR .....	1	36	TSC12001	STRAIN RELIEF .....	1
14	TSC07009	* SCREW (M2 X 12 mm) .....	1	37	S1603005B1	BLADE ADAPTER .....	2
15	S1601010	BEVEL SCALE .....	1	38	TSC07004	* SCREW (M5 X 25 mm) .....	1
16	TSC11004	* SPRING WASHER (M5) .....	3	39	TSC11009	* WASHER (M4) .....	4
17	S1601008	SPRING .....	1	40	S1603005B2	CLAMP JAW .....	2
18	TSC11008	* WASHER (M6) .....	3	41	TSC07016	* SCREW (4.2 X 10 mm) .....	1
19	TSC07001	* SCREW (M6 X 40 mm) .....	1	42	S1603005B3	SPRING .....	2
20	S1604005	SPRING .....	1	43	S1603004C	THROAT PLATE .....	1
21	S1604001	BLADE TENSION ASSEMBLY .....	1	44	S1601016A	TABLE LOCK KNOB .....	1
22	S1602001B2	LOWER ARM .....	1	45	S1603003	BLADE .....	2
23	TSC11005	* SPRING WASHER (M4) .....	6	46	TSC07011	* SCREW (M4 X 16 mm) .....	2

**WARNING: Improper repair of a double insulated tool can result in damage to the double insulation system possibly causing electrical shock or electrocution. Any repairs requiring disassembly of your tool requires safety testing and should only be performed by a Ryobi Authorized Service Center. For the service center nearest you call 1-800-525-2579.**

\* Standard Hardware Item – May Be Purchased Locally

## RYOBI 16 in. (406 mm) SCROLL SAW – MODEL SC164VS

The model number will be found on a plate attached to the motor housing. Always mention the model number in all correspondence regarding your **Scroll Saw** or when ordering repair parts.

### PARTS LIST

Key No.	Part Number	Description	Qty.	Key No.	Part Number	Description	Qty.
47	S1601014	DROP FOOT .....	1	74	TSC07018	* SCREW (4.2 X 13 mm) .....	4
48	TSC11001	* TOOTH WASHER (M5) .....	1	75	S1601023D	COVER PLATE .....	1
49	TSC09001	ROLL PIN .....	4	76	S1603008	T-HANDLE HEX KEY (3 mm) .....	1
50	S1605006M	SWITCH PLATE .....	1	77	S1604011	BLADE CLAMP SCREW .....	2
51	S1605001H	MOTOR .....	1	78	S1603009	ARM BEARING COVER .....	4
52	S1602005B	ECCENTRIC .....	1	79	S1605010	POTENTIOMETER .....	1
53	S1601007	SAW TABLE .....	1	80	TSC11010	* WASHER (M5) .....	1
54	TSC07006	* SCREW (M6 X 30 mm) .....	1	81	S1605011	VARIABLE SPEED KNOB .....	1
55	S1601018	PLASTIC TUBING .....	1	82	S1604010A	FOAM BUSHING .....	1
56	S1601015	ADJUSTMENT LEVEL .....	1	83	S1605001H1	CARBON BRUSH .....	2
57	S1601020	BELLOWS LOCK .....	1	84	S1605001H2	BRUSH CAP .....	2
58	S1601019	BELLOWS .....	1	85	TSC11011	* LOCK WASHER (M10) .....	1
59	TSC11002	* TOOTH WASHER (M4) .....	4	86	S1605003A1	SWITCH KEY .....	1
60	TSC07007	* SCREW (M8 X 8 mm) .....	1	87	TSC07019	* SCREW (M5 X 10 mm) .....	1
61	TSC07017	* SCREW (4.2 X 8 mm) .....	1	88	TSC14001	BEARING .....	2
63	TSC07012	* SCREW (M5 X 8 mm) .....	2	89	TSC06003	* HEX NUT (M10) .....	1
64	TSC07013	* SCREW (M4 X 6 mm) .....	2	90	S1606007F	SPEED INDICATION LABEL .....	1
65	TSC07014	* SCREW (M5 X 35 mm) .....	5	91	S160600411	DATA PLATE .....	1
66	TSC07015	* SCREW (M5 X 30 mm) .....	3	92	S1606003Z	WARNING LABEL .....	1
67	S1601017	DUST BLOWER .....	1	93	S1606002Z	LOGO PLATE .....	2
68	S1601011	DROP FOOT LOCK KNOB .....	1	94	S1606012A	BLADE WARNING LABEL .....	1
69	S16020022	BEARING RETAINER .....	1	95	S1606009	BLADE TENSIONING LABEL .....	1
70	S1601005	BOLT RETAINER .....	2	96	S16106001	GROUND LABEL .....	1
71	S1605005F	SWITCH BOX .....	1		983000-046	OPERATOR'S MANUAL	
72	S1605003A	ON/OFF SWITCH .....	1		983000-046R	REPAIR SHEET (REV:00)	
73	S1601032A	RUBBER FOOT .....	2		9-07-05		

\* Standard Hardware Item – May Be Purchased Locally

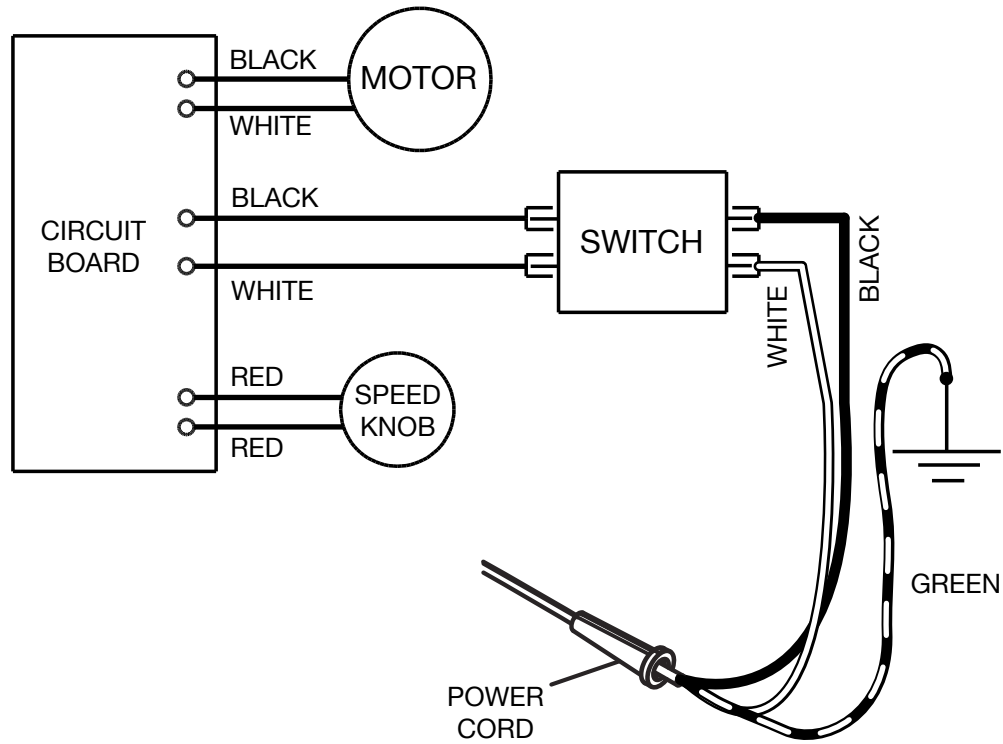

## WIRING DIAGRAM