

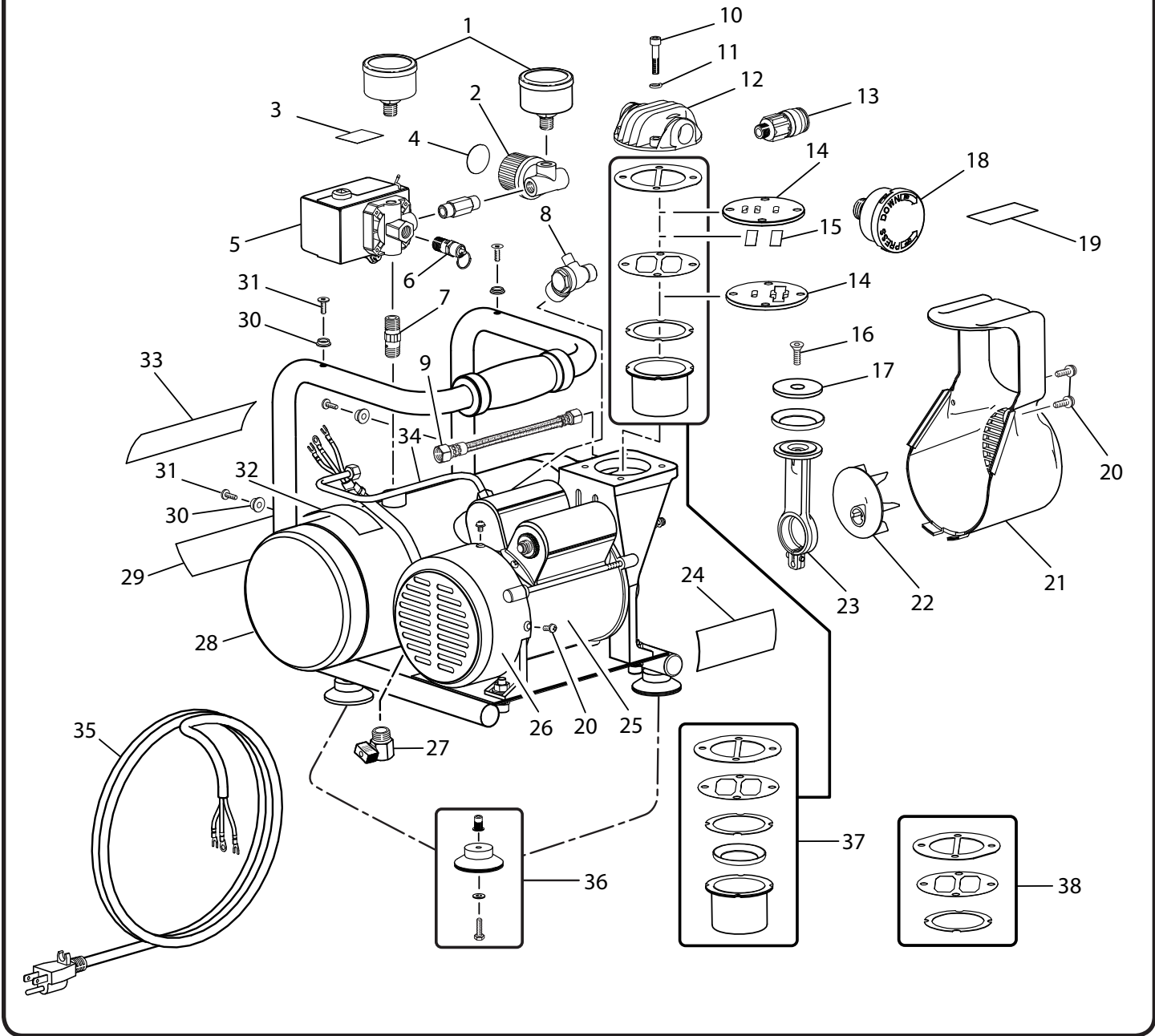

**Portable Air Compressor
Model No. H150PL
Repair Sheet**

HUSKY PORTABLE AIR COMPRESSOR - MODEL NO. H150PL



HUSKY PORTABLE AIR COMPRESSOR – MODEL NO. H150PL

The model number will be found on a plate attached to air tank. Always mention the model number in all correspondence regarding your **PORTABLE AIR COMPRESSOR** or when ordering replacement parts.

1	100205	GAUGE	2
2	100971	REGULATOR	1
3	102499	POWER LABEL	1
4	102500	REGULATOR KNOB LABEL	1
5	100957	PRESSURE SWITCH.....	1
6	102441	SAFETY VALVE.....	1
7	100853	NIPPLE (1/4 in. X 35 mm).....	2
8	101362	CHECK VALVE.....	1
9	102480	PRESSURE TUBE	1
10	100708	* BOLT (M6 X 30 mm)	4
11	100521	LOCK WASHER (M6).....	4
12	100227	HEAD	1
13	100307	QUICK CONNECT	1
14	100228	PLATE.....	2
15	100229	REED VALVE.....	2
16	100802	* SCREW (M6 X 16 mm)	1
17	100780	PISTON CAP	1
18	100794	AIR FILTER	1
19	102498	HOT SURFACE LABEL.....	1
20	102531	MOTOR COVER SCREW (M3 X 10 mm).....	5
21	101716	PUMP SHROUD	1
22	100776	FAN PUMP	1
23	100774	CONNECTING RING	1
24	102496	MOTOR LABEL	1
25	102433	PUMP MOTOR	1
26	100299	MOTOR SHROUD	1
27	101717	DRAIN VALVE	1
28	102474	FRAME/TANK ASSEMBLY	1
29	102501	WARNING LABEL.....	1
30	102529	MALE SNAP	4
31	102530	SCREW SNAP	4
32	102497	DATA LABEL	1
33	102495	TANK LABEL	1
34	102479	PRESSURE RELIEF TUBE	1
35	102481	CORD w/CLIP	1
36	101722	ISOLATOR KIT	1
37	101721	PUMP REBUILD KIT.....	1
38	101719	GASKET KIT	1

ITEMS NOT SHOWN:

FT-2501-CP	AIR HOSE.....	1
102537	AIR FILTER INSTALLATION LABEL	1
102538	LABEL WARNING SPANISH	1
3310054	TOOL BAG	1
987000148	OPERATOR'S MANUAL	1
09-06-07 (REV:00)		

* Standard Hardware Item – May Be Purchased Locally

HUSKY PORTABLE AIR COMPRESSOR – MODEL NO. H150PL

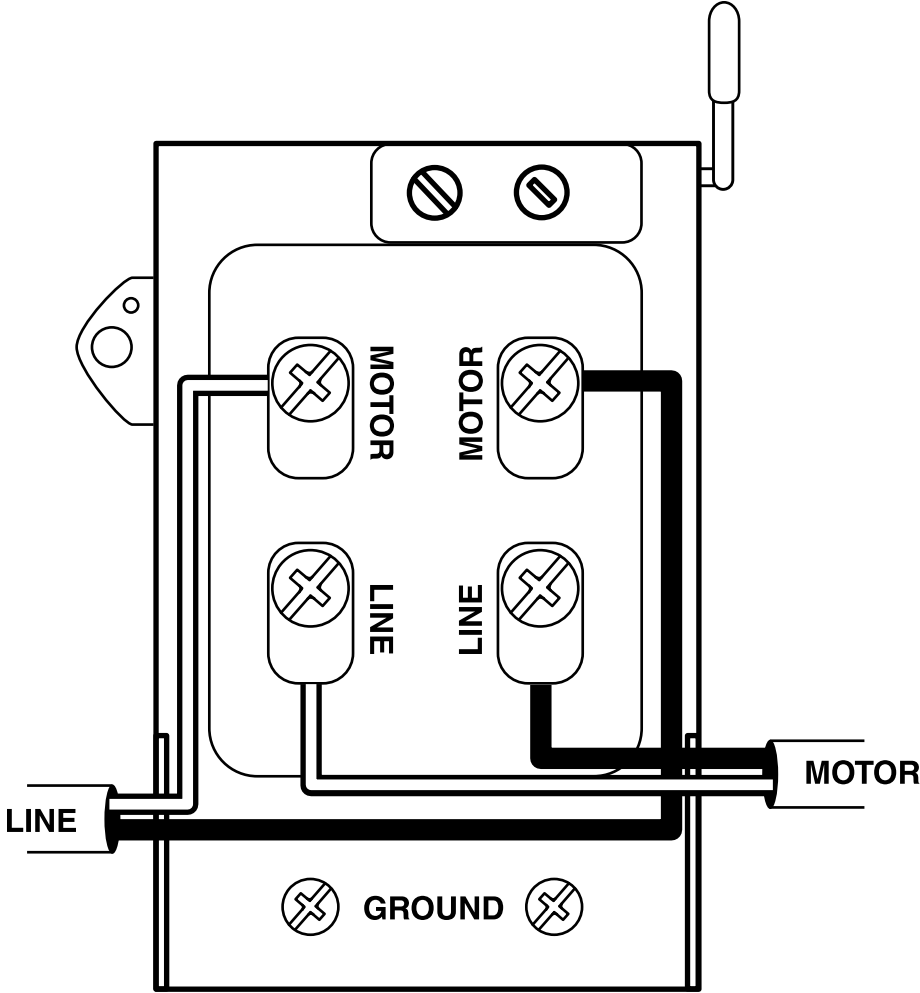

WIRING DIAGRAM