

RYOBI 10 in. (254 mm) TABLE SAW

MODEL NO. BTS20

REPAIR SHEET

RYOBI 10 in. (254 mm) TABLE SAW - MODEL NO. BTS20

FIGURE A: TABLE SAW ASSEMBLY

The model number will be found on the data plate attached to the cabinet. Always mention the model number in all correspondence regarding your **TABLE SAW** or when ordering repair parts.

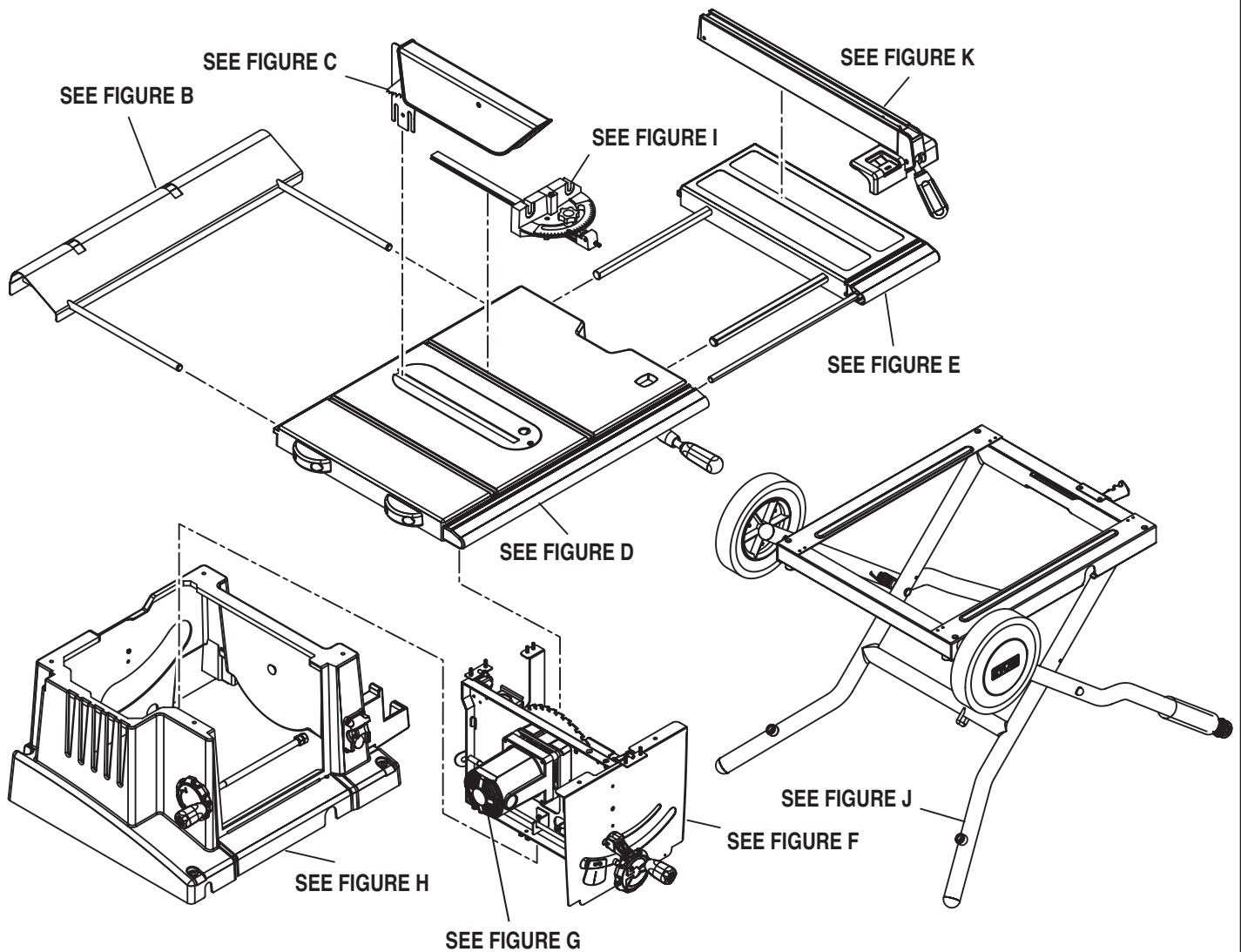

WARNING:

Improper electrical repair of the table saw can result in damage to the drive system possibly causing electrical shock or electrocution. Any repairs requiring disassembly of your tool require safety testing and should only be performed by a Ryobi Authorized Service Center.

RYOBI 10 in. (254 mm) TABLE SAW - MODEL NO. BTS20

FIGURE B: OUTFEED SUPPORT

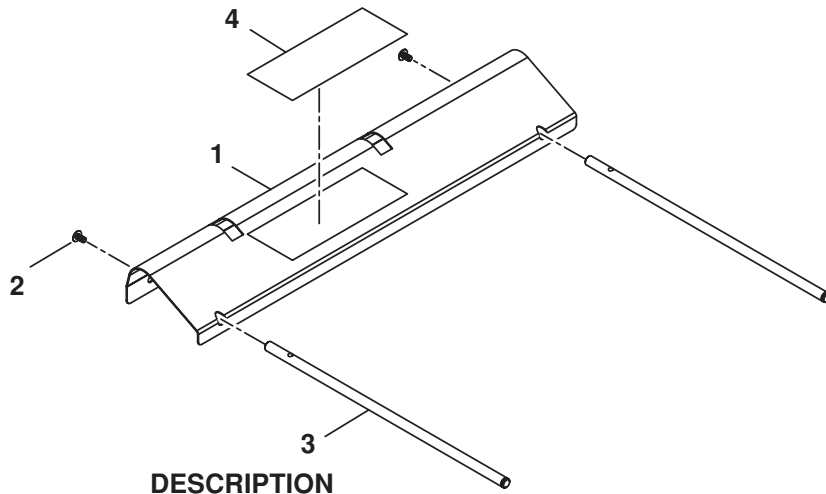

KEY NO.	PART NUMBER	DESCRIPTION	QTY.
1	0131010314	OUTFEED SUPPORT	1
2	410551701	SCREW (1/4-20 x 1/2 in.)	2
3	0131010809	OUTFEED SUPPORT ROD	2
4	9131015335702	OUTFEED LABEL	1

FIGURE C: BLADE GUARD

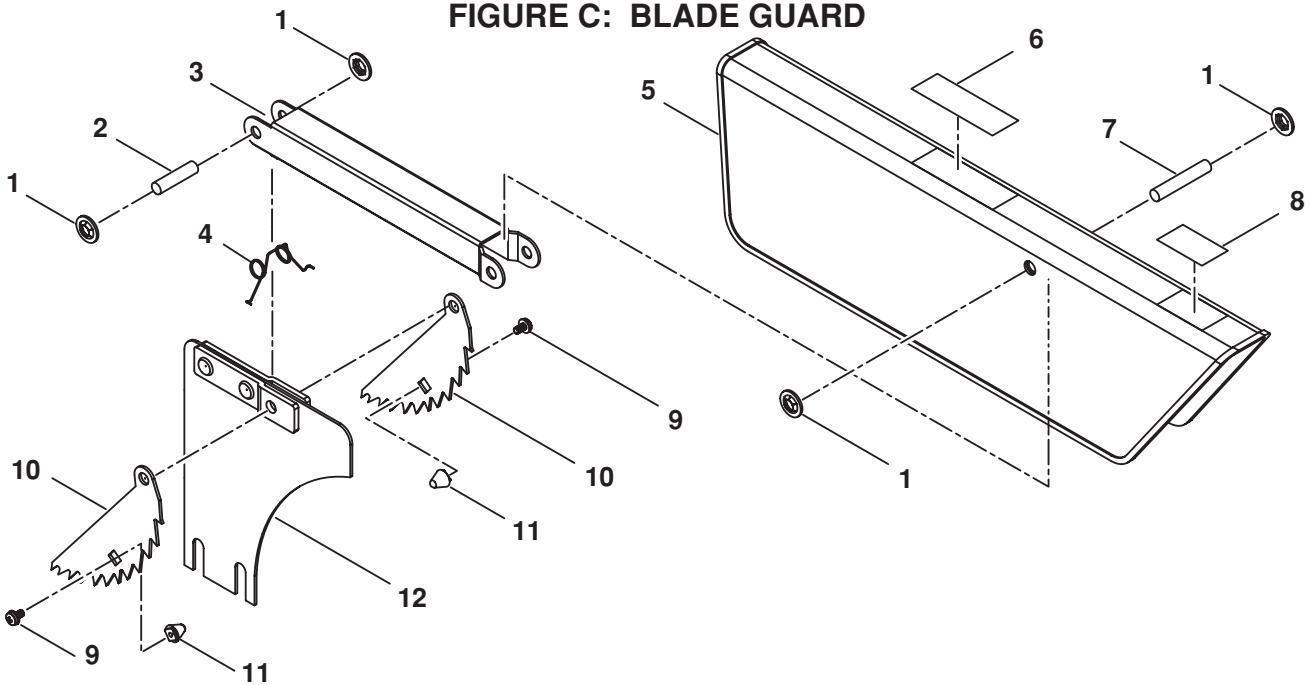

KEY NO.	PART NUMBER	DESCRIPTION	QTY.
1	411105701	PUSH NUT (5/16 in.)	4
2	0131010910	PIN (5/16 in. x 1-1/4 in.)	1
3	0131010303	ARM	1
4	0181010902	TORSION SPRING	1
5	0131010204	BLADE GUARD	1
6	9181015330201	WARNING LABEL	1
7	0131010911	PIN (5/16 in. x 1-3/4 in.)	1
8	9181015330202	WARNING LABEL	1
9	0181010801	SCREW AND WASHER (M4 x 7mm)	2
10	0181010303	ANTI-KICK BACK PAWL	2
11	0181010202	SPACER CAP	2
12	0131010304	RIVING KNIFE	1

RYOBI 10 in. (254 mm) TABLE SAW - MODEL NO. BTS20
FIGURE D: TABLE

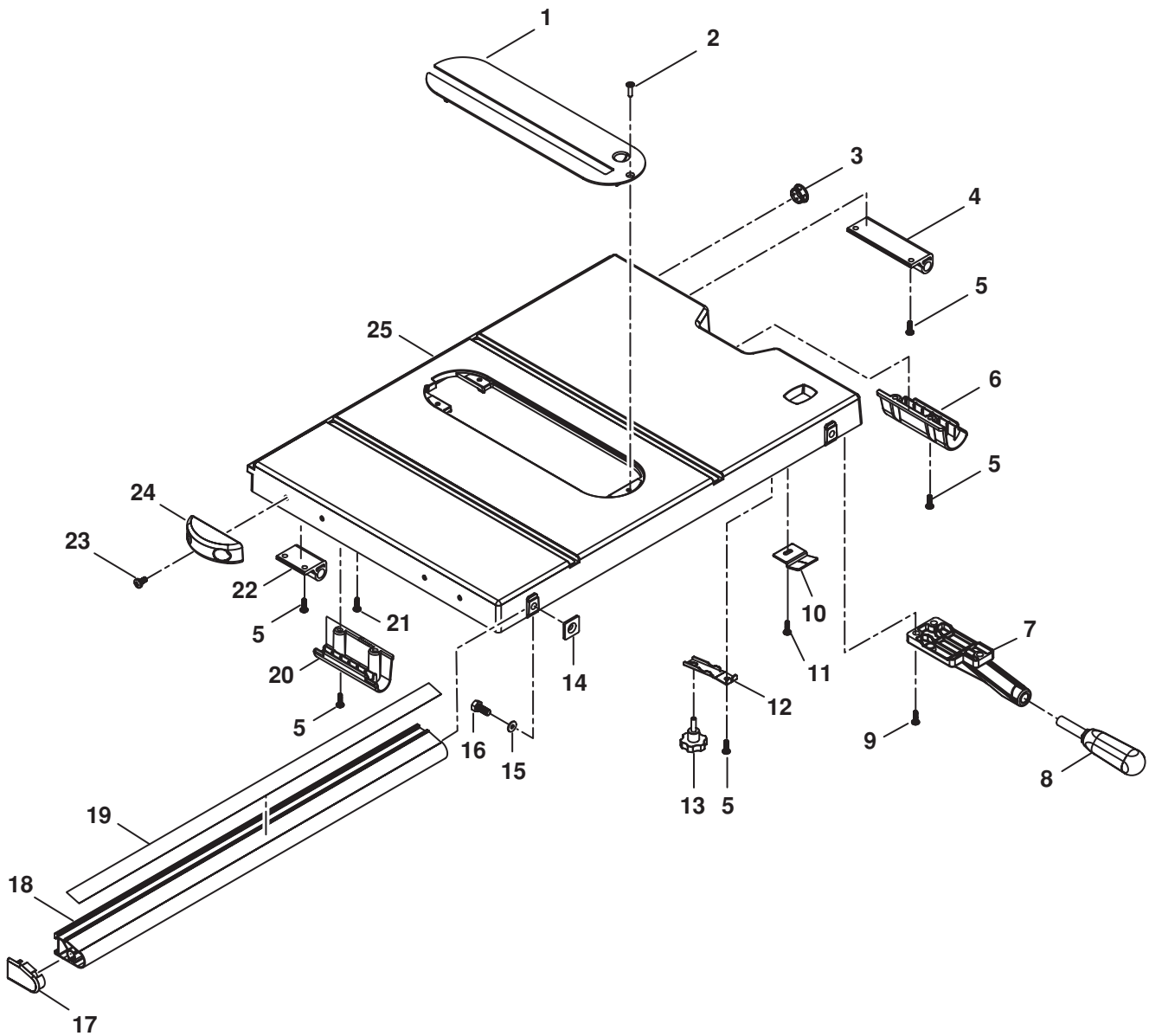

KEY NO.	PART NUMBER	DESCRIPTION	QTY.
1	0131010316-35	THROAT PLATE	1
2	410101012	SCREW (#10-24 x 3/4 in.)	1
3	0131010228	BUSHING	2
4	0131011806	OUTFEEDER BRACKET, RIGHT	1
5	410171706	SCREW (#10-24 x 1/2 in.)	4
6	0131010221	CARRY HANDLE (RIGHT)	1
7	0131010108-94	AUXILIARY HANDLE BRACKET	1
8	0181010227	AUXILIARY HANDLE	1
9	0131010814	HEX HD SCREW (M6 x 25mm)	4
10	0131010214	EXTENSION ROD INDICATOR	1
11	410331002	SCREW (M4 x 10)	1

RYOBI 10 in. (254 mm) TABLE SAW - MODEL NO. BTS20

PARTS LIST - FIGURE D (CONT'D): TABLE

KEY NO.	PART NUMBER	DESCRIPTION	QTY.
12	0131010321	CLAMP PLATE, EXTENSION ROD	2
13	0131010225	KNOB, EXTENSION ROD CLAMP PLATE	2
14	0181010317	NUT	2
15	412011065	WASHER (D8 x D16 x 0.8T)	2
16	410011703	HEX HD SCREW (5/16-18UNC x 5/8 in.)	2
17	0131010219	END CAP (LEFT)	1
18	0131011802	MAIN RAIL	1
19	9131015330301	SCALE, MAIN RAIL	1
20	0131010229	CARRY HANDLE (LEFT)	1
21	410192001	SCREW (4 x 10mm)	4
22	0131011805	OUT FEEDER BRACKET (LEFT)	1
23	410131722	SCREW (1/4-20UNC x 1/2 in.)	4
24	0131010224	BUMPER	2
25	0131010105	TABLE	1

FIGURE E: EXTENSION TABLE

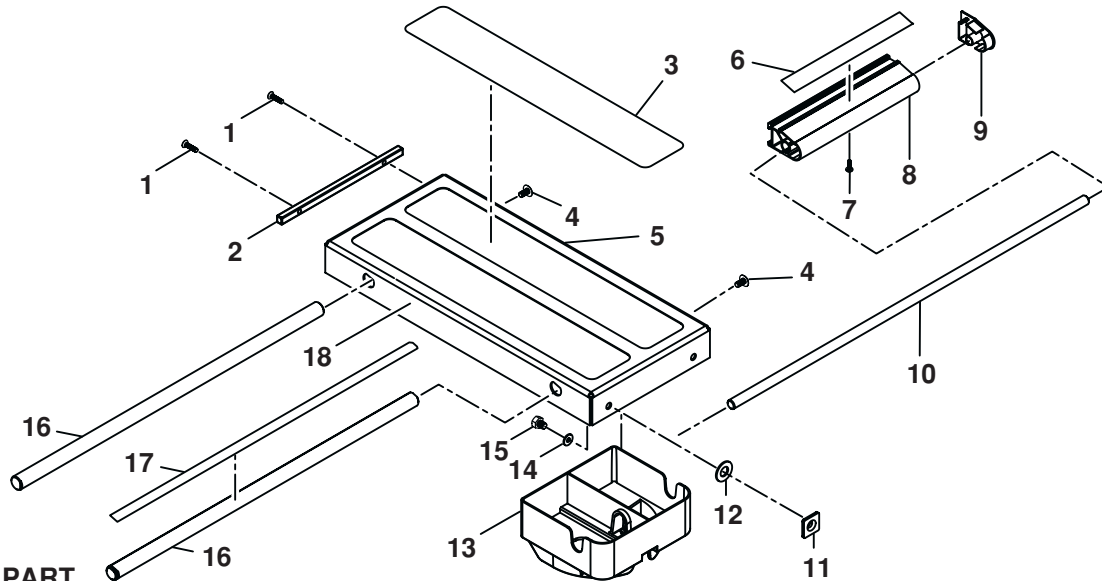

KEY NO.	PART NUMBER	DESCRIPTION	QTY.
1	410101012	SCREW (#10-24UNC)	2
2	0131010807	SQUARE BAR	1
3	9131015335703	TEAR-DOWN LABEL	1
4	410551701	SCREW AND WASHER (1/4-20UNC x 1/2 in.)	2
5	9131015335704	SET-UP LABEL	1
6	9131015330302	SCALE, SMALL RAIL	1
7	410132730	SCREW (#8-32UNC x 5/8 in.)	1
8	0131011804	SMALL RAIL	1
9	0131010223	END CAP (RIGHT)	1
10	0131010808	JOINT BAR	1
11	0181010317	RAIL WASHER	2
12	412011076	WASHER (D12.8 x D26 x 2.5T)	2
13	0131010220	MITER GAUGE HOLDER	1
14	412011065	WASHER (D8 x D16 x 0.8T)	2
15	410011720	HEX SCREW (5/16-18UNC x 3/8 in.)	2
16	0131010806	EXTENSION ROD	2
17	9131015330303	EXTENSION ROD SCALE	1
18	0131010313	EXTENSION TABLE	1

RYOBI 10 in. (254 mm) TABLE SAW - MODEL NO. BTS20
FIGURE F: LOCKER BRACKET

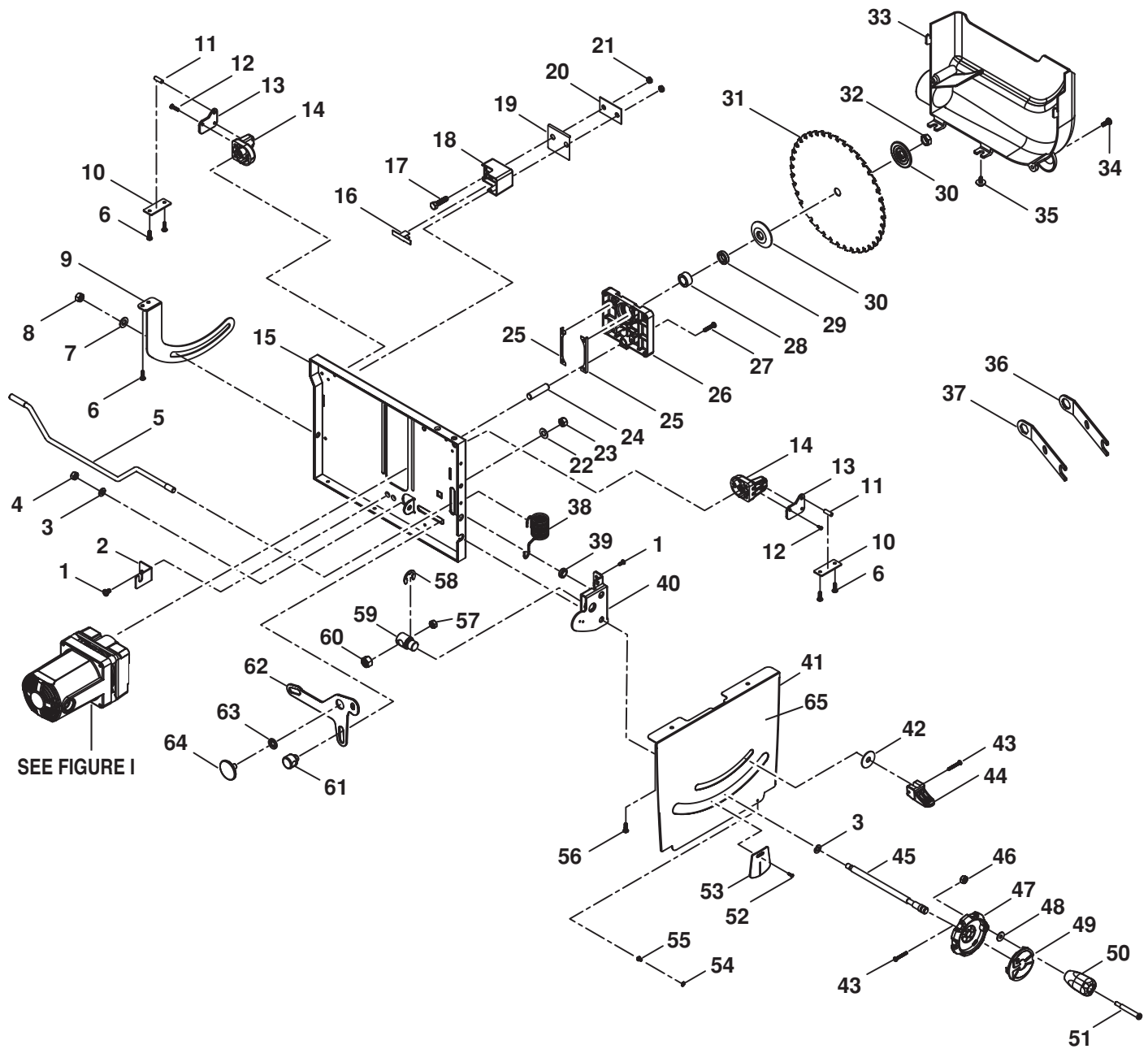

KEY NO.	PART NUMBER	DESCRIPTION	QTY.
1	410132728	SCREW (1/4-20UNC x 3/8 in.)	4
2	0131010311	SUPPORTER	1
3	412012706	WASHER (D8 x D16 x 0.8T)	2
4	411072006	NYLON NUT (M8)	1
5	0131010905	CRANK	1
6	410171706	TAPPING SCREW (#10-24UNC x 7/2)	14
7	412012074	WASHER (D10 x D26 x 2T)	1
8	411072004	NYLON NUT (M10)	1
9	0131010308	REAR LINKAGE	1
10	0181010323	CLAMP PLATE	2
11	0181010905	NEEDLE ROLLER	2

RYOBI 10 in. (254 mm) TABLE SAW - MODEL NO. BTS20
PARTS LIST - FIGURE F (CONT'D): LOCKER BRACKET

KEY NO.	PART NUMBER	DESCRIPTION	QTY.
12	410171706	SCREW (#10-24UNC x 1/2 in.)	1
13	0181010312	PIVOT PLATE	2
14	0131010103	PIVOT SUPPORT	2
15	0131010306	LOCKER BRACKET	1
16	0181010320	FIX PLATE	1
17	410011718	HEX HD. SCREW (5/16-18UNC x 1-1/4 in.)	2
18	0131010106	RIVING KNIFE DECK	1
19	0181010343	SHIM	5
20	0181010321	RIVING CLAMP	1
21	411011710	HEX NUT (5/16-18UNC)	2
22	412012706	WASHER (3/8 x 20mm x 2T)	1
23	411072709	NYLON NUT (3/8-16UNC)	1
24	414050007	PIN (12 x 25mm)	1
25	0131010302	SHIM	2
26	0131010107	GEAR BOX	1
27	410141701	SCREW AND WASHER (#10-24UNC x 1 in.)	4
28	0181010504	1/2in. SPACER	1
29	0181010503	1/4in. SPACER	1
30	0181010401	BLADE WASHER	2
31	422010040	BLADE (10 in. x 5/8 in. X 36T)	1
32	0131010912	ARBOR NUT (5/8-18NF-2B)	1
33	0131010205	DUST COVER	1
34	410131724	SCREW (1/4-20UNC x 5/8 in.)	2
35	410332703	SCREW (1/4-20UNC x 5/8 in.)	2
36	0131010319	WRENCH	1
37	0131010318	WRENCH	1
38	0131010913	SPRING	1
39	0131010914	SPACER	1
40	0131010310	BRACKET	1
41	0131010312-58	FRONT PANEL	1
42	412012075	WASHER (D10 x 34 x 1.6T)	1
43	410132719	SCREW (#8-32UNC x 1-3/16 in.)	2
44	0131010227	BEVEL LOCKER	1
45	0131010804	GEAR SHAFT (HEIGHT)	1
46	411072702	NYLON NUT (1/4-20)	1
47	0131010206	FRONT HAND WHEEL	1
48	412011712	WASHER (1/4 x 13 x 1.5)	1
49	0101140206	CAP, FRONT HAND WHEEL	1
50	0131010208	WHEEL HANDLE	1
51	0101140203	BOLT, HAND WHEEL	1
52	410331008	SCREW (M4 X 10)	2
53	0131010215	BEVEL INDICATOR	1
54	412041002	STAR WASHER (M4)	1
55	410131023	SCREW (M4 x 6mm)	1
56	0181010814	SCREW (#10-24UNC x 1/2 in.)	2
57	411011003	HEX NUT (M8)	2
58	413051008	E-CLIP (E-15)	1
59	0131010906	BLOCK	1
60	0131010927	NUT	2
61	0131010301	DRIVE BLOCK	1
62	0131010305	DRIVE PLATE	1
63	0131010907	WASHER	1
64	0131010803	SCREW (3/8-16UNC x 1/2 in.)	1
65	9131015330101	NAME PLATE LABEL	1

RYOBI 10 in. (254 mm) TABLE SAW - MODEL NO. BTS20

FIGURE G: MOTOR

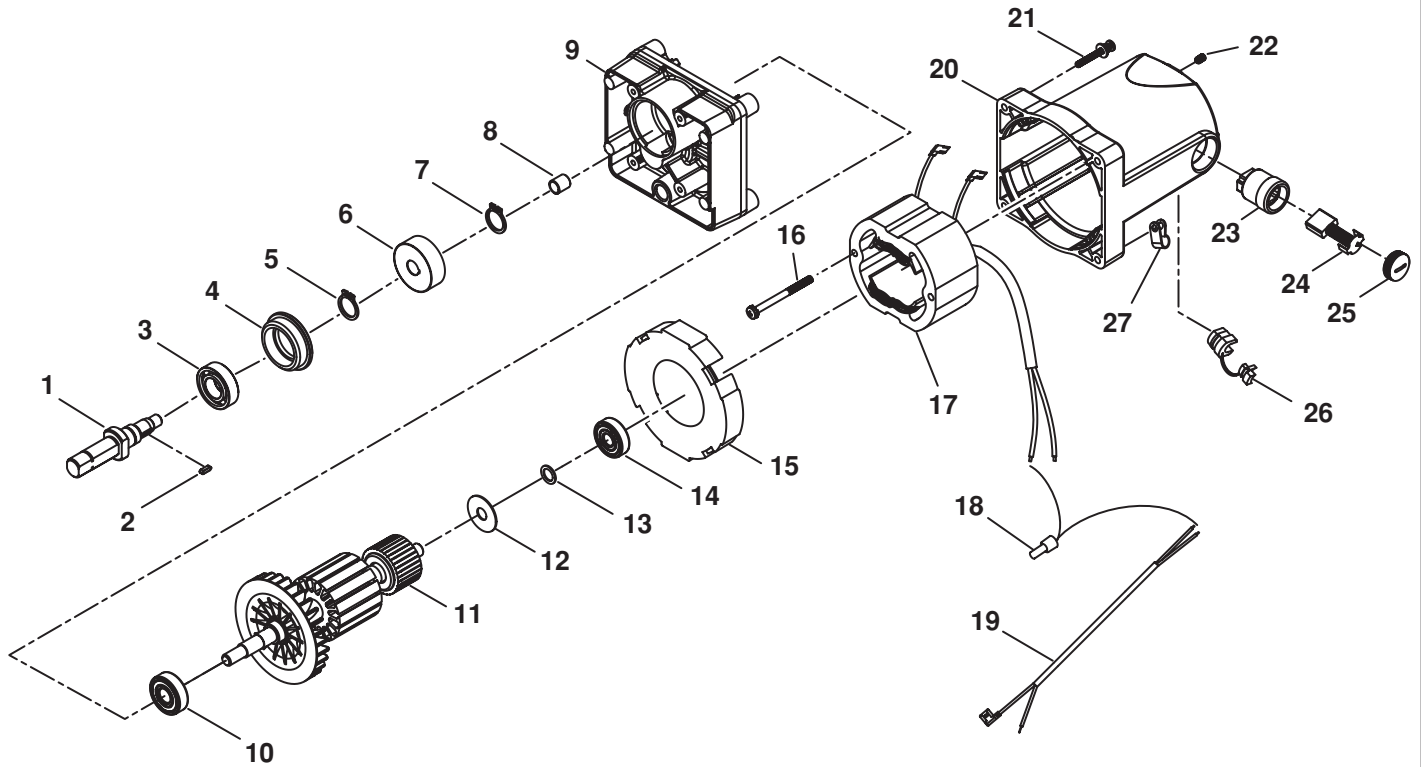

KEY NO.	PART NUMBER	DESCRIPTION	QTY.
1	0131010602	ARBOR	1
2	415030001	KEY (3 x 3 x 10mm)	1
3	420010003	BEARING (6002LU, Z)	1
4	0101010505	BEARING BUSHING	1
5	413011001	C-CLIP (S15)	1
6	0131011001	REDUCTION GEAR	1
7	413011009	C-CLIP (S13)	1
8	420110001	NEEDLE BEARING (HK0910)	1
9	0131010101	GEAR BOX	1
10	420010001	BEARING (6201LLU CM,5C)	1
11	A131010301	ARMATURE ASSEMBLY	1
12	0181010344	INSULATION PLATE	1
13	0181010307	INSULATION PLATE	1
14	420010004	BEARING (6200LU CM,5C)	1
15	0131010202	BAFFLE	1
16	410462002	SCREW AND STAR WASHER (M5 x 60)	2
17	A131010401	FIELD	1
18	451020002	WIRE NUT (TM-3, C5)	2
19	0131010701	POWER CORD	1
20	0131010201	MOTOR HOUSING	1
21	410271701	SCREW AND WASHER (3/16-32UNF x 1-3/8 in.)	4
22	410071004	SET SCREW (M5 x 10mm)	2
23	0502020221	BRUSH HOLDER ASSEMBLY	2
24	0502025002	BRUSH ASSEMBLY	2
25	0602200209	BRUSH CAP	2
26	451010001	STRAIN RELIEF BUSHING (AVC SB6R-3, 6B3-2R)	1
27	0301030202	WIRE CLAMP (5/16 in. ACC-2.5)	1

RYOBI 10 in. (254 mm) TABLE SAW - MODEL NO. BTS20

FIGURE H: CABINET

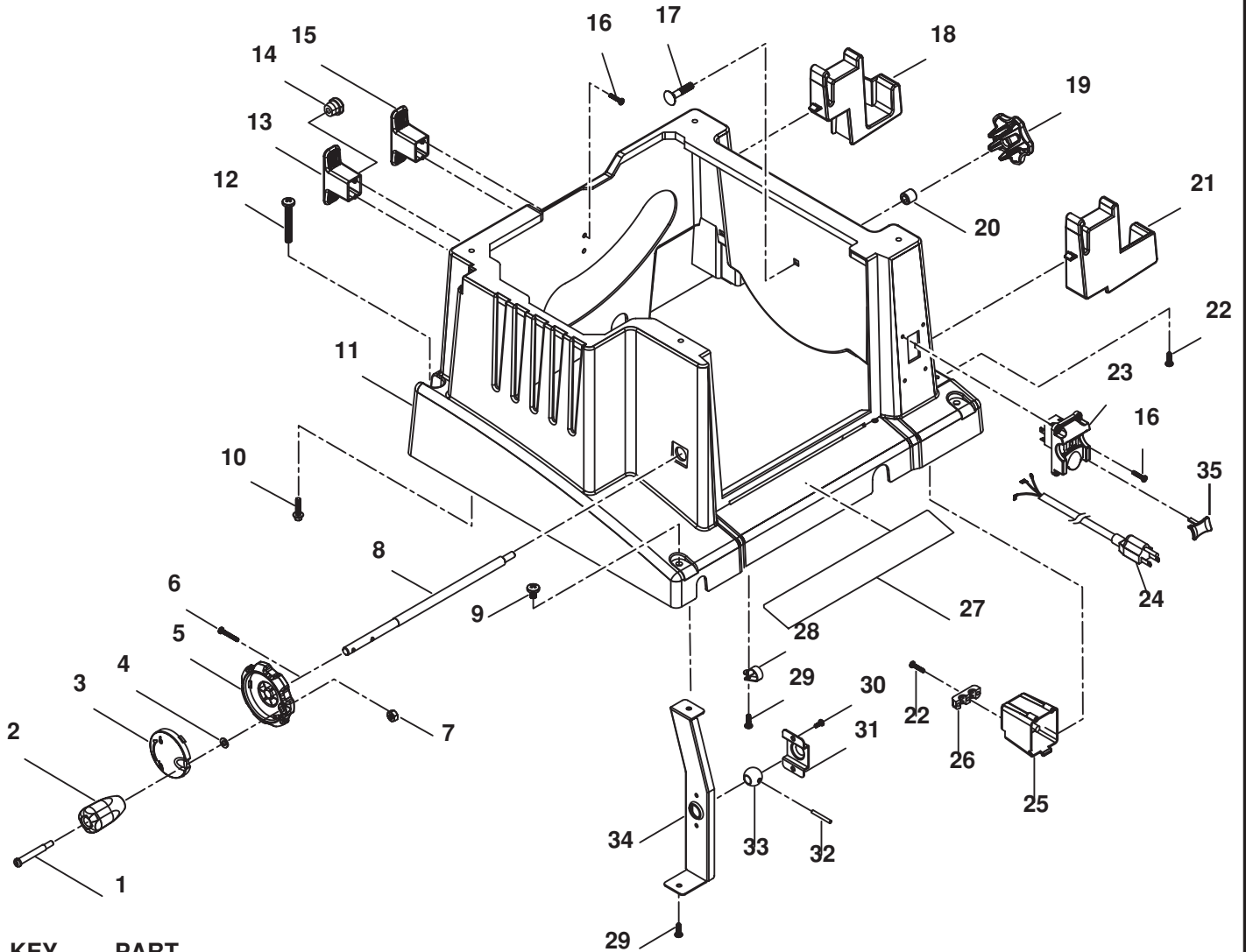

KEY NO.	PART NUMBER	DESCRIPTION	QTY.
1	0101140203	BOLT, HAND WHEEL	1
2	0131010208	WHEEL HANDLE	1
3	0131010207	CAP, BEVEL WHEEL	1
4	412011712	WASHER (1/4 x 13 x 1.5)	1
5	0131010206	FRONT HAND WHEEL	1
6	410132719	SCREW (#8-32UNC x 1-3/16 in.)	1
7	411072702	NYLON NUT (1/4-20)	1
8	0131010805	SCREW ROD	1
9	0131010815	TORQUE SCREW (5/16-18UNC x 1/2 in.)	2
10	410161008	LOCK SCREW (M6 x 25)	4
11	0131010203-42	CABINET	1
12	0131010816	TORQUE SCREW (5/16-18UNC x 1-1/4 in.)	2
13	0131010217-39	CABLE MANAGEMENT (LEFT)	1
14	0131010219	END CAP	1
15	0131010222-39	CABLE MANAGEMENT (RIGHT)	1
16	410191005	SCREW (M4 x 20mm)	8
17	410031710	CARRIAGE BOLT (5/16-18UNC x 1-1/2 in.)	1
18	0131010212-42	FENCE HANGER (REAR)	1
19	0171010215	KNOB, BLADE STORAGE	1
20	0171010216	SPACER, BLADE STORAGE	1
21	0131010211-42	FENCE HANGER (FRONT)	1

RYOBI 10 in. (254 mm) TABLE SAW - MODEL NO. BTS20

PARTS LIST - FIGURE H (CONT'D): CABINET

KEY NO.	PART NUMBER	DESCRIPTION	QTY.
22	410451703	SCREW (#8-16UNC x 3/4 in.)	7
23	984406-001	SWITCH	1
24	0131010702	CABLE	1
25	0131010209	SWITCH BOX	1
26	0131010210	CABLE CLAMP	1
27	9131015330201	WARNING LABEL	1
28	0301030202	WIRE CLAMP (5/16S)	4
29	410451701	SCREW (#8-16UNC x 1/2 in.)	5
30	410132728	SCREW (1/4-20UNC x 3/8 in.)	2
31	0131010328	PLATE	1
32	414011021	SPRING PIN (M4 x 24mm)	1
33	0131010926	BALL	1
34	0131010320	REINFORCE PLATE	1
35	984406-003	SWITCH KEY	1

FIGURE I: MITER GAUGE

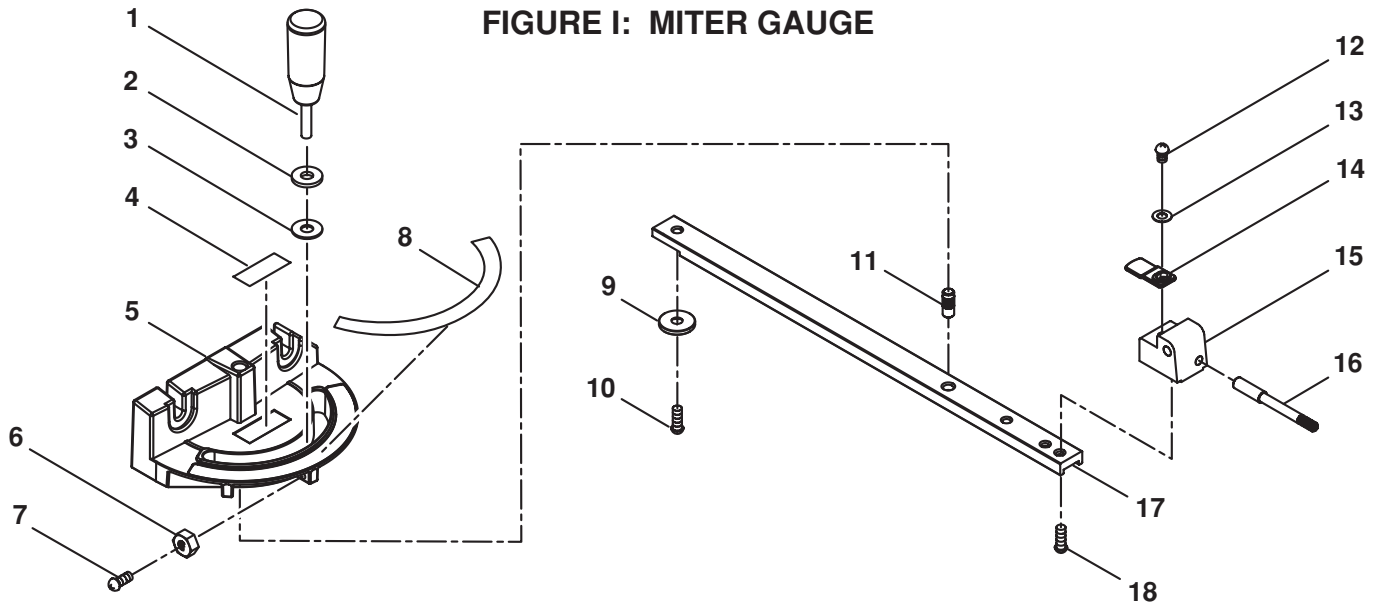

KEY NO.	PART NUMBER	DESCRIPTION	QTY.
1	0131010236	KNOB	1
2	412012705	WASHER	1
3	412080702	NYLON WASHER	1
4	9131015330102	LOGO LABEL	1
5	0131010109-94	MITER GAUGE HEAD	1
6	411012704	HEX NUT	3
7	410132703	SCREW	3
8	9131015330304	MITER SCALE	1
9	0131010928	MITER SLIDER WASHER	1
10	410102014	SCREW (M6 x 8mm)	1
11	0101010917	CENTER PIN	1
12	410132704	SCREW	1
13	412012004	WASHER	1
14	0131010329	MITER INDICATOR	1
15	0101010108	INDICATOR DECK	1
16	0101010918	INDEX PIN	1
17	0131011807	BAR	1
18	410102701	SCREW	2

**RYOBI 10 in. (254 mm) TABLE SAW - MODEL NO. BTS20
FIGURE J: STAND**

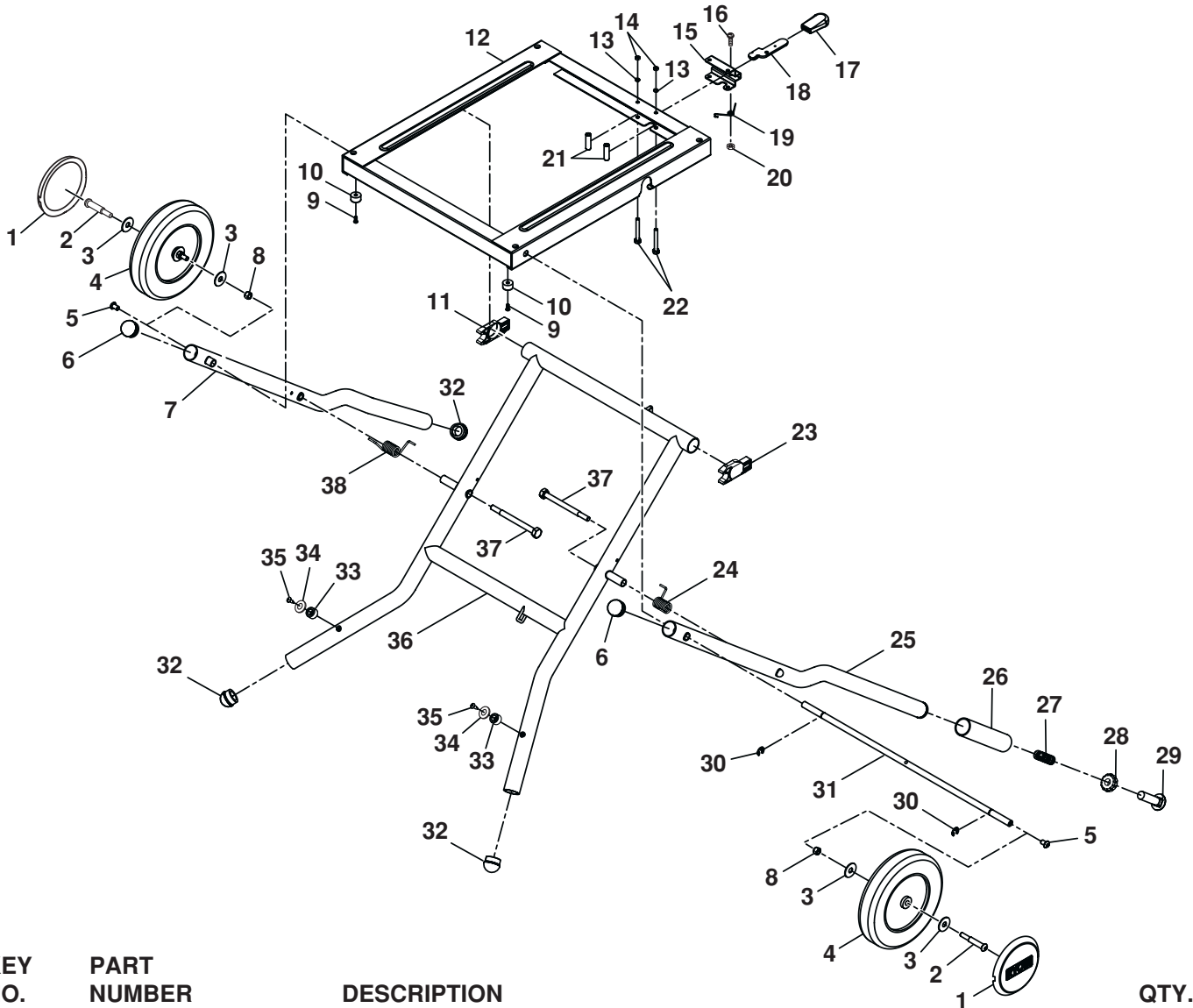

KEY NO.	PART NUMBER	DESCRIPTION	QTY.
1	0131010234	WHEEL CAP	2
2	0131010812	SHOULDER BOLT	2
3	412011085	WASHER	4
4	0131010235	8 in. WHEEL	2
5	410492704	HEX SCREW (5/16-18UNC* 12.7mm)	2
6	0131010233	CAP	2
7	A131016302	REAR LEG	1
8	412011085	NUT	2
9	410131731	SCREW (1/4-20UNC x 1/2))	4
10	0131011302	PAD	4
11	0131010230	SLIDER	1
12	A131017001	SLIDER FRAME	1
13	412041702	STAR WASHER (1/4 in.)	2
14	411011707	HEX NUT (1/4 in.)	2
15	0131010323	LATCH	1
16	0131010810	SCREW	1
17	0131011301	LATCH COVER	1
18	0131010322	LATCH BAR	1
19	0131010915	LATCH SPRING	1
20	411071702	HEX NUT (1/4 in.)	1
21	0131010923	PIN	2
22	410011722	HEX SCREW (1/4-20UNC x 2 in.)	2

RYOBI 10 in. (254 mm) TABLE SAW - MODEL NO. BTS20

PARTS LIST - FIGURE J (CONT'D): STAND

KEY NO.	PART NUMBER	DESCRIPTION	QTY.
23	0131010231	SLIDER	1
24	0131010916	TORSION SPRING	1
25	A131016301	FRONT LEG	1
26	0131011304	HANDLE TUBE	1
27	0131010918	ADJUST SPRING	1
28	0131010232	ADJUST RING	1
29	410032714	CARRIAGE BOLT (5/8-11UNC* 63.5mm)	1
30	413061001	C-CLIP (CTW46)	2
31	0131010813	LINKAGE ROD	1
32	0131011303	PAD	4
33	0131011302	PAD	4
34	412011025	WASHER	4
35	410131731	SCREW (1/4-20UNC x 1/2 in.)	4
36	A131016303	SLIDE LEG	1
37	0131010811	SCREW	2
38	0131010917	SPRING (REAR)	1

FIGURE K: RIP FENCE

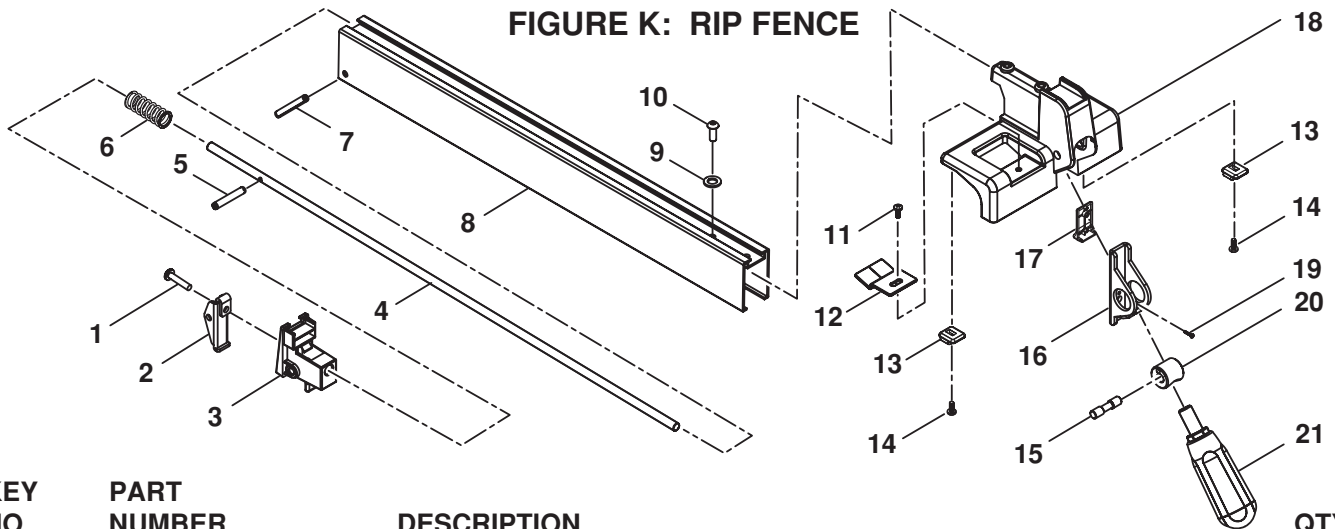

KEY NO.	PART NUMBER	DESCRIPTION	QTY.
1	410139719	NYLOCK SCREW (10#-24UNC x 1 in.)	1
2	0131010317	CLAMPER - B	1
3	0131010218	REAR DECK	1
4	0131010908	PUSH ROD	1
5	414011023	ROLL PIN (1/8 X 3/4)	1
6	0181010907	SPRING	1
7	414050008	PIN (D6 X 33.7)	1
8	0131011801	RIP FENCE RAIL	1
9	412011064	WASHER (D7 X D16 X 1.5T)	2
10	410491703	SCREW (1/4in. - 20UNC x 5/8 in.)	2
11	410331002	SCREW AND WASHER (M4 x 10 SEMS)	1
12	0131010216	SCALE INDICATOR	1
13	0131010213	SLIDER	2
14	410171709	SCREW (#8-32UNC x 9mm)	2
15	0131010909	PIN	1
16	0131010315	CLAMPER - A	1
17	0131010226	BLOCK	1
18	0131010104-94	FRONT BLOCK	1
19	410192012	SCREW (M3 x 8mm)	1
20	0181010506	ECCENTRIC ROLLER	1
21	0181010227	LOCKING HANDLE	1