

**RYOBI**  
**9 in. BAND SAW**  
**MODEL NO. BS903**  
**REPAIR SHEET**

RYOBI 9 in. BAND SAW - MODEL NUMBER BS903

FIGURE A

2

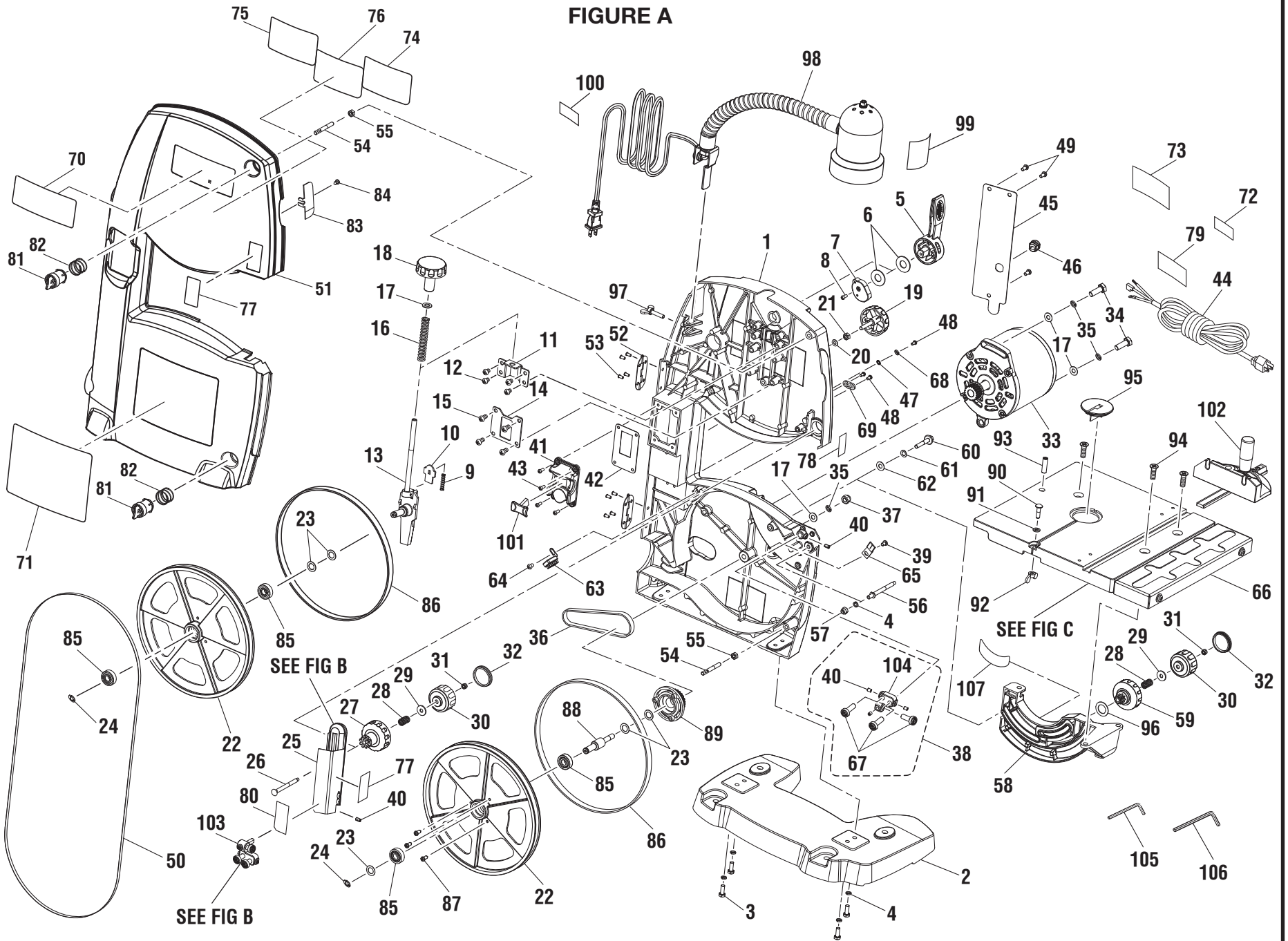

## RYOBI 9 in. BAND SAW – MODEL NUMBER BS903

The model number will be found on a plate attached to the motor housing. Always mention the model number in all correspondence regarding your **BAND SAW** or when ordering repair parts.

### PARTS LIST FOR FIGURE A

KEY NO.	PART NUMBER	DESCRIPTION	QTY.	KEY NO.	PART NUMBER	DESCRIPTION	QTY.
1	224072000	FRAME .....	1	27	303652000	BLADE GUIDE ADJUSTMENT KNOB.....	1
2	240064000	BASE.....	1	28	029138000	TENSION SPRING .....	2
3	020301013	* SCREW (M6 X 16 mm).....	4	29	089140301123	WASHER.....	3
4	021200001	* LOCK WASHER (1/4 in.) .....	5	30	303653000	LOCK KNOB .....	2
5	303649000	BLADE TENSION LEVER .....	1	31	022301001	* NYLON LOCK NUT (M5 X 0.8 mm).....	2
6	021118002	WASHER.....	2	32	303695000	LOCK KNOB END CAP.....	2
7	060043000	CAM ASSEMBLY .....	1	33	900984000	MOTOR ASSEMBLY .....	1
8	826632	* SCREW (M4 X 10 mm PAN HD.).....	1	34	020314003	* SCREW (M8 X 25 mm).....	2
9	029185001	COMPRESSION SPRING (M5.5 X 30) .....	1	35	021204001	* LOCK WASHER (5/16 in.) .....	3
10	270683000	SLIDE .....	1	36	041002000	GEAR TYPE BELT .....	1
11	270677000	SLIDE PLATE.....	1	37	022505000	NUT .....	1
12	020102023	* SCREW (M6 X 8 mm).....	4	38	080007005704	LOWER BLADE GUIDE ASSEMBLY (INC. KEY NOS. 40, 67 AND 104) .....	1
13	900982000	UPPER WHEEL SUPPORT ASSEMBLY .....	1	39	816755-4	SCREW (M5 X 9 mm PAN HD.).....	1
14	270678000	PLATE.....	1	40	080007005060	* SET SCREW (M5 X 6 mm) .....	8
15	020102025	* SCREW (M6 X 12 mm).....	4	41	984406001	SWITCH (INC. KEY NO. 101) .....	1
16	029186001	COMPRESSION SPRING (M10.7 X 80) .....	1	42	270689000	SWITCH COVER.....	1
17	821063-2	WASHER (8 X 16 X 1.2) .....	4	43	089140301008	* SCREW (M4 X 10 mm PAN HD.).....	4
18	303650000	BLADE TENSION KNOB .....	1	44	080406002	POWER CORD (SJT 18 AWG X 36 75°) .....	1
19	303651000	TRACKING KNOB.....	1	45	270679000	PLATE COVER .....	1
20	021101008	WASHER (M6 X 1).....	1	46	913001000	STRAIN RELIEF .....	1
21	022111002	* LOCK NUT (M6) .....	1	47	813314-5	* LOCK WASHER (M4) .....	1
22	080007005706	WHEEL ASSEMBLY .....	2	48	020103031	* SCREW (M4 X 8 mm).....	3
23	021504009	WASHER .....	4	49	813313-4	* SCREW (M5 X 12 mm PAN HD.).....	3
24	023102001	* RETAINING RING .....	2	50	351009000	SAW BLADE (1/4 in. X 6T X 59-1/4 in.).....	1
25	080007005034	BLADE GUARD ASSEMBLY (SEE FIGURE B) (INC. KEY NOS. 40, 77, 80 AND 103) .....	1	51	303655000	COVER .....	1
26	020911001	* CARRIAGE BOLT (M6 X 72.5 mm).....	1	52	270680000	HINGE .....	2

**WARNING: Improper repair of a double insulated tool can result in damage to the double insulation system possibly causing electrical shock or electrocution. Any repairs requiring disassembly of your tool requires safety testing and should only be performed by a Ryobi Authorized Service Center. For the service center nearest you call 1-800-525-2579.**

\* Standard Hardware Item – May Be Purchased Locally

**RYOBI 9 in. BAND SAW – MODEL NUMBER BS903**

The model number will be found on a plate attached to the motor housing. Always mention the model number in all correspondence regarding your **BAND SAW** or when ordering repair parts.

**PARTS LIST FOR FIGURE A CONTINUED**

KEY NO.	PART NUMBER	DESCRIPTION	QTY.	KEY NO.	PART NUMBER	DESCRIPTION	QTY.
53	024201000	RIVET .....	8	82	029187001	COMPRESSION SPRING .....	2
54	290270000	LOCK PIN .....	2	83	303657000	TRACKING VIEW WINDOW .....	1
55	022111007	* NUT (M6 X 4.8 mm).....	2	84	020132001	* SCREW (M4 X 10 mm SELF-TAPPING).....	1
56	028977000	TRUNNION SHAFT LOCK .....	1	85	050013000	BEARING .....	4
57	022306000	* NYLON NUT (M6).....	1	86	330023000	TIRE .....	2
58	080007005083	SAW TABLE BRACKET (TRUNNION).....	1	87	020132000	* SCREW (M4 X 13 mm SELF-TAPPING).....	3
59	303660000	ANGLE ADJUSTMENT KNOB .....	1	88	290273000	LOWER WHEEL SHAFT.....	1
60	028976000	SHOULDER SCREW w/ WASHER HEAD .....	1	89	303665000	IDLER PULLY .....	1
61	021403-007	WAVY WASHER .....	1	90	028967000	* SCREW (M6 X 25 mm TRUSS HD.).....	1
62	021103010	WASHER .....	1	91	021101011	WASHER.....	1
63	900987000	BRUSH.....	1	92	089140301122	* WING NUT (M6) .....	1
64	020103031	* SCREW (M4 X 8 mm).....	1	93	020505031	* SET SCREW (M8 X 18 mm) .....	1
65	303658000	SCALE INDICATOR .....	1	94	080007005131	* SCREW (M8 X 25 mm).....	3
66	080007005705	TABLE ASSEMBLY (SEE FIGURE C).....	1	95	303659000	THROAT PLATE (TABLE INSERT).....	1
67	080007005056	SHAFT ASSEMBLY .....	3	96	021118001	WASHER .....	1
68	021201003	* LOCK WASHER (M4) .....	1	97	020401000	* WING SCREW (M6 X 25 mm) .....	1
69	303006000	CORD CLAMP .....	1	98	901001000	WORK LIGHT.....	1
70	863209000	LOGO LABEL .....	1	99	080007005165	LIGHT WARNING LABEL.....	1
71	863209001	WARNING LABEL .....	1	100	080007005164	CORD TAG LABEL .....	1
72	871057000	DATA LABEL.....	1	101	984406003	KEY SWITCH .....	1
73	863209002	BLADE TRACKING & ADJUSTING LABEL .....	1	102	900988000	MITER GAUGE ASSEMBLY .....	1
74	863209007	BLADE CHART (FRENCH) .....	1	103	080007005052	UPPER BLADE GUIDE ASSEMBLY .....	1
75	863209009	BLADE CHART (ENGLISH) .....	1	104	080007005055	LOWER SUPPORT GUIDE.....	1
76	863209010	BLADE CHART (SPANISH).....	1	105	089140301155	HEX KEY (2.5 mm) .....	1
77	863209003	KEEP HANDS AWAY WARNING LABEL.....	2	106	98209600	HEX KEY (4.0 mm) .....	1
78	863209004	TRACKING VIEW WINDOW .....	1	107	080007005168	TRUNNION SCALE LABEL .....	1
79	863209005	LOCK LABEL .....	1		983000979	OPERATOR'S MANUAL	
80	870037000	DEPTH SCALE .....	1		9-25-08		
81	303656000	LATCH (DOOR LOCK KNOB).....	2		(REV:02)		

**WARNING: Improper repair of a double insulated tool can result in damage to the double insulation system possibly causing electrical shock or electrocution. Any repairs requiring disassembly of your tool requires safety testing and should only be performed by a Ryobi Authorized Service Center. For the service center nearest you call 1-800-525-2579.**

\* Standard Hardware Item – May Be Purchased Locally

FIGURE B

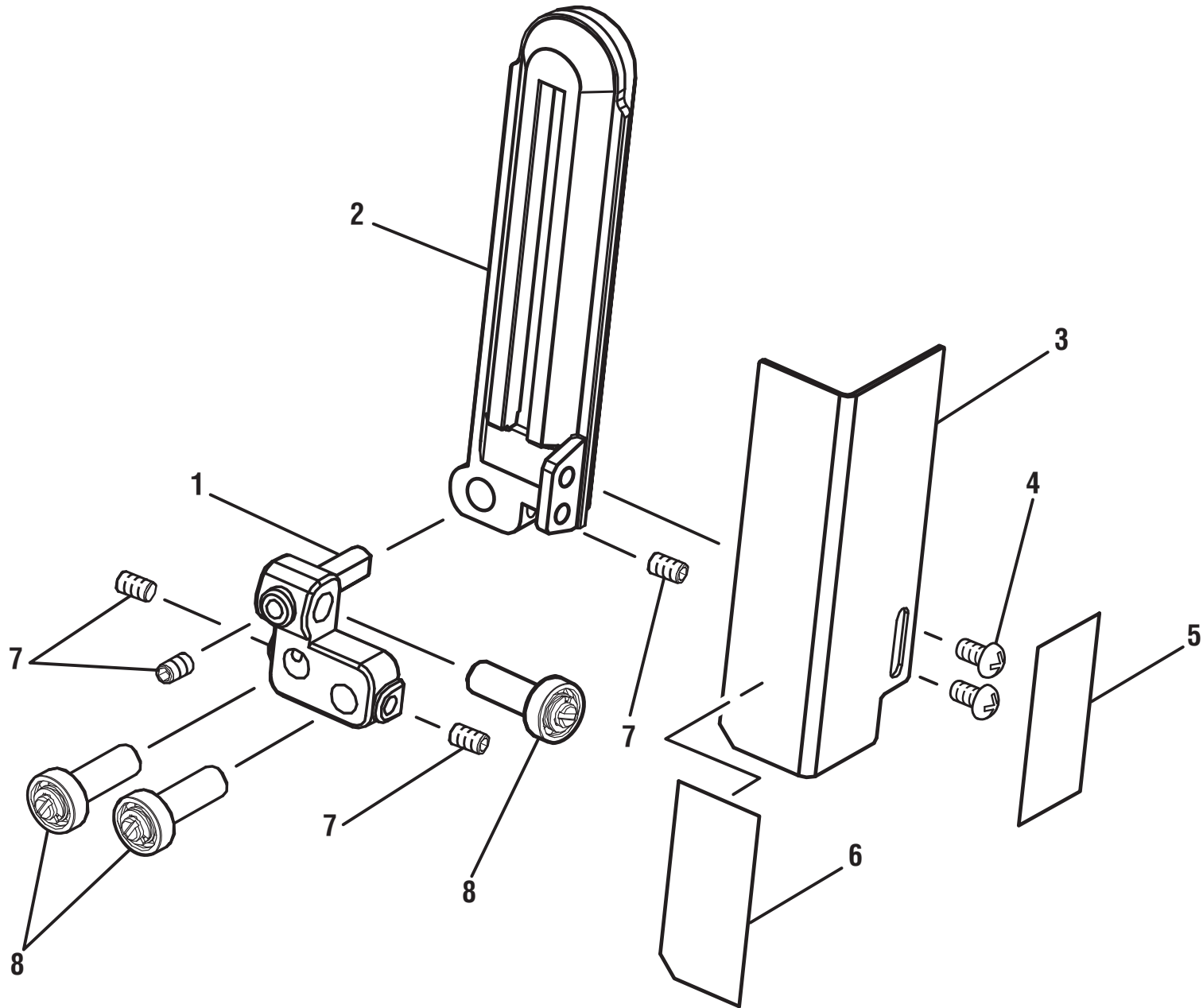

**RYOBI 9 in. BAND SAW – MODEL NUMBER BS903**

The model number will be found on a plate attached to the motor housing. Always mention the model number in all correspondence regarding your **BAND SAW** or when ordering repair parts.

**PARTS LIST FOR FIGURE B**

<b>KEY NO.</b>	<b>PART NUMBER</b>	<b>DESCRIPTION</b>	<b>QTY.</b>
1	080007005054	UPPER BLADE GUIDE SUPPORT .....	1
2	080007005035	BLADE GUIDE .....	1
3	080007005036	BLADE GUARD SHIELD .....	1
4	816755-4	* SCREW (M5 X 9 mm PAN HD.) .....	2
5	863209003	WARNING LABEL (NO HANDS) .....	1
6	870037000	DEPTH SCALE.....	1
7	080007005060	* SCREW (M5 X 6 mm HEX SOCKET HD.).....	4
8	080007005056	BLADE GUIDE ASSEMBLY .....	3

**WARNING:** Improper repair of a double insulated tool can result in damage to the double insulation system possibly causing electrical shock or electrocution. Any repairs requiring disassembly of your tool requires safety testing and should only be performed by a Ryobi Authorized Service Center. For the service center nearest you call 1-800-525-2579.

\* Standard Hardware Item – May Be Purchased Locally

FIGURE C

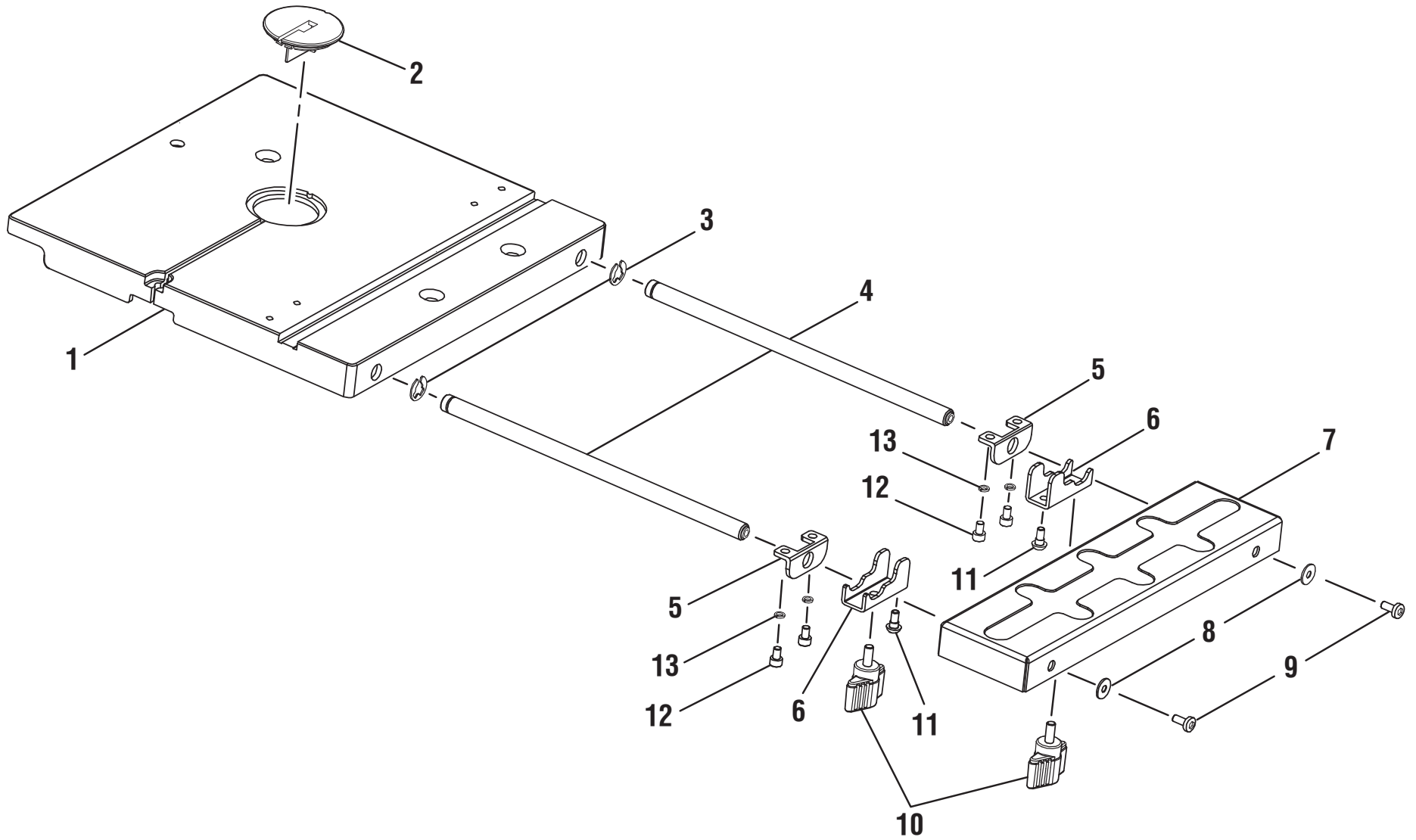

**RYOBI 9 in. BAND SAW – MODEL NUMBER BS903**

The model number will be found on a plate attached to the motor housing. Always mention the model number in all correspondence regarding your **BAND SAW** or when ordering repair parts.

**PARTS LIST FOR FIGURE C**

KEY NO.	PART NUMBER	DESCRIPTION	QTY.
1	080007005093	SAW TABLE .....	1
2	303659000	THROAT PLATE (TABLE INSERT) .....	1
3	080007005098	RETAINING RING .....	2
4	080007005095	TABLE LEVER .....	2
5	080007005099	TABLE BRACKET .....	2
6	080007005101	TABLE FRAME BRACKET .....	2
7	080007005094	SLIDING TABLE EXTENSION .....	1
8	080007005096	WASHER (M5).....	2
9	820240-6	* SCREW (M5 X 12 mm HEX SOCKET HD.).....	2
10	080007005102	TABLE EXTENSION KNOBS.....	2
11	080007005103	SCREW (M5).....	2
12	080007005100	* SCREW (M5 X 8 mm HEX SOCKET HD.).....	4
13	080007005104	LOCK WASHER (M5).....	4
	080007005705	COMPLETE TABLE ASSEMBLY (INC. KEY NOS. 1-13)	

8

**WARNING: Improper repair of a double insulated tool can result in damage to the double insulation system possibly causing electrical shock or electrocution. Any repairs requiring disassembly of your tool requires safety testing and should only be performed by a Ryobi Authorized Service Center. For the service center nearest you call 1-800-525-2579.**

\* Standard Hardware Item – May Be Purchased Locally