

### PARTS LIST FOR RIDGID 10" RADIAL SAW MODEL NUMBER RS10000

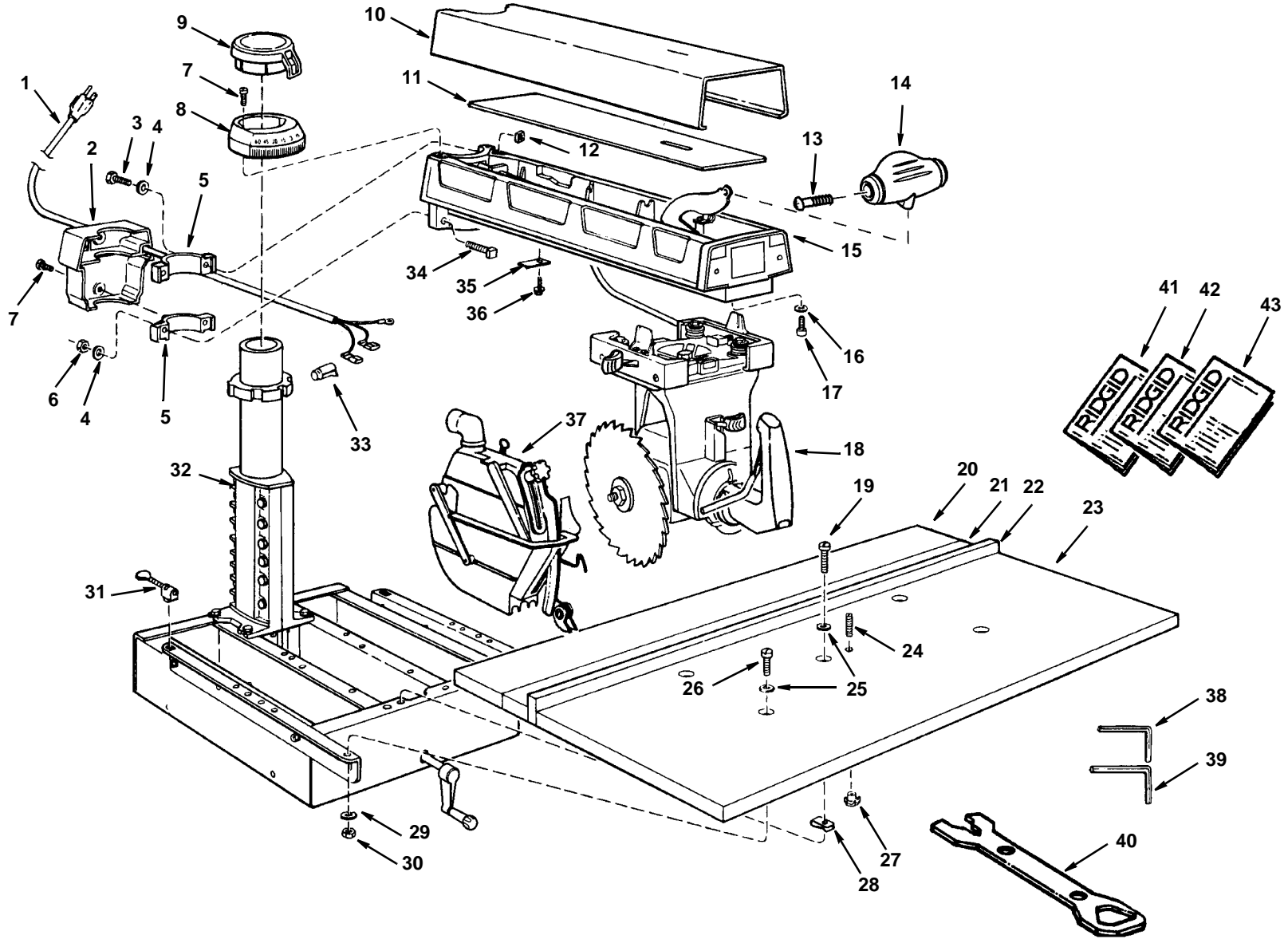

Figure 1

**PARTS LIST FOR RIDGID 10" RADIAL SAW  
MODEL NUMBER RS10000**

**Always order by Part Number - Not by Key Number**

**Figure 1**

<b>Key No</b>	<b>Part No.</b>	<b>Description</b>
1	804423-1	Cord, with Plug
2	75090	Cover, Rear Arm
3	60342	Bolt Square Head 3/8-16 x 2-1/4 High Strength
4	60353	Washer, .380 x 47/64 x 1/8
5	815649	Bearing, Arm
6	60249	Nut, Lock 3/8-16
7	13848	Screw, Pan Rec. Hd 10-32 Ty T x 1/2
8	827922	Scale, Miter
9	827923	Indicator, Miter
10	827905	Trim Arm
11	63686	Pad, Trim
12	805494	Nut, Square 3/8-16
13	60391	Screw, Pan Rec. Ty AB 10 x 3/4
14	827924	Knob, Lever Arm
15	—	Arm Assembly, See Fig. 5
16	131201	Lockwasher, 5/16
17	9421620	Screw, Soc. Hd Cap 5/16-18 x 1/2
18	—	Yoke Assembly, See Fig. 2
19	809491-6	Screw, Pan Hd 1/4-20 x 1-3/4
20	822079	Table, Rear
21	822080	Table, Spacer

<b>Key No.</b>	<b>Part No.</b>	<b>Description</b>
22	63432	Fence, Rip
23	822078	Table, Front
24	141667-33	Screw, Set SL. Cup 1/4-20 x 1
25	805552-7	Washer, 17/64 x 5/8 x 1/32
26	809491-1	Screw, Pan Hd 1/4-20 x 1
27	145544	Nut, Tee
28	37530	Nut, "U" Clip
29	115109	Lockwasher, 1/4
30	115120	Nut, Hex 1/4-20
31	826284	Clamp Assembly
32	—	Base Assembly, See Fig. 3
33	63467	Cap, Flag Terminal
34	60339	Bolt, Sq. Hd 3/8-16 x 2-1/4 Gr 5
35	63881	Clamp, Cord
36	9420417	Screw, Type "T" Hex Washer Hd 1/4-20 x 5/8
37	—	Guard Assembly, See Fig. 4
38	63683	Wrench, Hex "U" 3/16
39	63682	Wrench, Hex "U" 1/4
40	822384-1	Wrench
41	SP6263	Owners Manual - English
42	SP6263S	Owners Manual - Spanish
43	SP6263F	Owners Manual - French

\* Standard Hardware Item - May Be Purchased Locally

## PARTS LIST FOR RIDGID 10" RADIAL SAW MODEL NUMBER RS10000

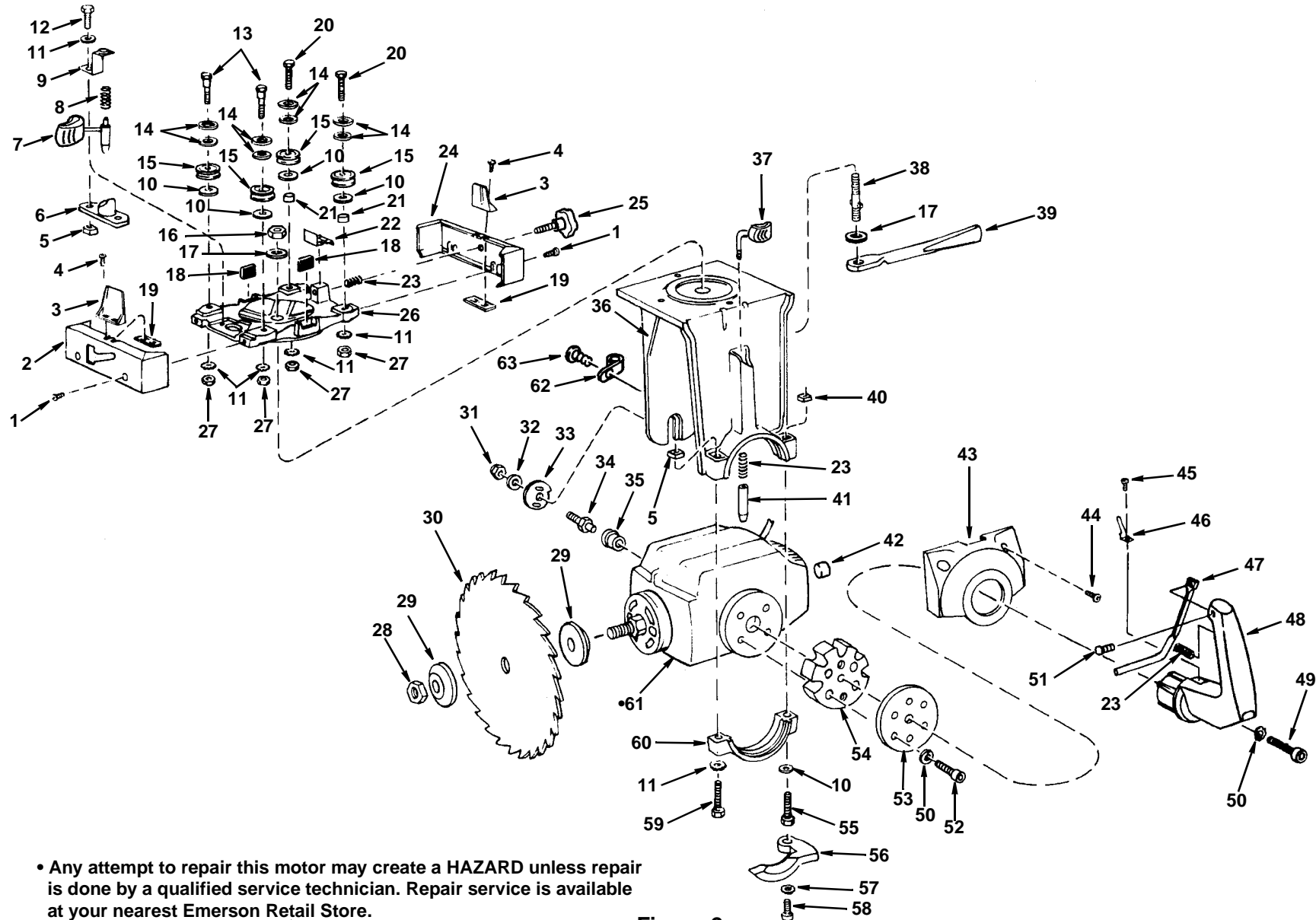

• Any attempt to repair this motor may create a HAZARD unless repair is done by a qualified service technician. Repair service is available at your nearest Emerson Retail Store.

Figure 2

**PARTS LIST FOR RIDGID 10" RADIAL SAW  
MODEL NUMBER RS10000**

**Always order by Part Number - Not by Key Number**

**Figure 2 - Yoke Assembly**

Key No.	Part No.	Description	Key No.	Part No.	Description
1	13848	* Screw, Type "T" Pan Rec. Hd10-32 x 1/2	33	63652	Cam, Motor
2	827884	Cover, L.H. Carriage	34	63651	Stud, Motor
3	827880	Indicator, Rip	35	63469	Bushing, Rubber
4	809813-1	* Screw, Pan Rec. Hd 6-32 x 1/2	36	821356-1	Yoke
5	120399	Nut, Square 5/16-18	37	827901	Knob, Bevel Index
6	63657	Housing, Index Pin	38	63643	Stud, Yoke Clamp
7	827903	Pin Assembly, Index	39	805874-1	Handle, Yoke Lock
8	63658	Spring, Index	40	822180	Nut, Square L.H. 5/16-18
9	63656	Bracket, Spring	41	63645	Pin, Index
10	60040	* Washer, 21/64 x 3/4 x 1/16	42	129530	Cap, Shaft
11	131201	* Lockwasher, 5/16, Ext. Tooth	43	63620	Trim, Yoke
12	805467-4	* Screw, Hex Hd 5/16-18 x 3/4	44	60337	* Screw, Type "T" Pan Rec. Hd 10-32 x 7/8
13	815807-1	Screw, Eccentric	45	809492	* Screw, Type "T" Pan Rec. Hd 8/32 x 5/16
14	63782	Washer Assembly, Carriage Bearing	46	806179-1	Indicator, Bevel
15	819039	Bearing, Carriage	47	821354	Trigger
16	161255-7	* Nut, Lock 5/8-11	48	821342	Handle, Yoke
17	37816	* Washer, .630 x 1. 125 x .093	49	9421628	Screw, Soc. Cap 5/16-18 x 2
18	30567	Bumper	50	131201	* Lockwasher, 5/16
19	30530	Nut, Speed	51	60288	Screw, Locking Set 1/4 - 20 x 3/8
20	60336	Bolt, Hex Hd 5/16-18 x 1-1/2 High Strength	52	9421626	Screw, Soc. Cap 5/16-18 x 1-1/2
21	63779	Bearing, Sleeve	53	805802	Plate, Retainer
22	63528	Shoe, Rip Lock	54	63649	Ring, Index
23	30521	Spring, Swivel Latch	55	60335	Screw, Hex Hd L.H. 5/16-18 x 2
24	827885	Cover, R.H. Carriage	56	63647	Lever, Bevel Lock
25	827904	Knob, Carriage Lock	57	114603	* Lockwasher, Ext. Tooth No. 10
26	63641	Carriage	58	806214	Screw, Hex Soc. Button Hd Cap 10-32 x 5/8
27	805482	* Nut Hex Jam 5/16-18	59	451188	* Screw, Hex Hd 5/16-18 x 2
28	128880	Nut, Shaft	60	810362-1	Cap, Yoke
29	804667-1	Collar Blade	61	827894	Motor
30	828172	Blade, Saw	62	810659	Clamp, Cord
31	60249	* Nut, Lock 3/8-16	63	809492-2	Screw, Pan TY "T" 8-32 x 1/2
32	60039	* Washer, .380 x 47/64 x 1/16			

\* Standard Hardware Item - May be purchased locally

† Stock Item - May be secured through the hardware departments of many retail stores

• Any attempt to repair this motor may create a HAZARD unless repair is done by a qualified service technician. Contact your nearest Service Center.

**Repair Parts**



**PARTS LIST FOR RIDGID 10" RADIAL SAW  
MODEL NUMBER RS10000**

**Always order by Part Number - Not by Key Number**

**Figure 3 - Base Assembly**

Key No.	Part No.	Description
1	102593	* Screw, Soc. Set 3/8-16 x 1/2
2	63623	Latch, Arm
3	60330	Ring, Retaining 3"
4	805793	Tube Column
5	63610	Gib, Column Tube
6	456299	* Pin, Roll 1/4 x 1
7	821346	Nut, Elevation
8	9416187	* Screw, Type "T" Hex Washer Hd. 5/16-18 x 3/4
9	805467-6	* Screw, Hex Hd. 5/16-18 x 1
10	60078	* Screw, Hex Hd. 5/16-18 x 1/2
11	118615	* Nut, Hex 3/8-16
12	187077	* Lockwasher, 3/8
13	60340	* Washer, .380 x 7/8 x 1/8
14	9415743	* Screw, Hex Hd. 3/8-16 x 1-1/4
15	186648	* Screw, Hex Hd. 5/16-18 x 1-7/8
16	817398-1	Screw, Locking Cap 1/4-20 x 5/8
17	60367	Bolt, Hex Hd. 5/16-18 x 1-7/8 High Strength
18	60336	Bolt, Hex Hd. 5/16-18 x 1-1/2 High Strength
19	805838-1	Support, L.H.
20	828329	Shaft, Elevating
21	63500	Washer, Thrust .502 x.927 x .031
22	63614	Bearing

Key No.	Part No.	Description
23	60300	Washer, 1/2 x 7/8 x.01 0 (as required)
24	828332	Gear, Bevel
25	805839-1	* Nut, Lock 1/2-13
26	805857-1	Support, R.H.
27	805482	* Nut, Hex 5/16-18
28	802352	* Nut, Lock 5/16-18
29	805642	* Ring, Retaining 1/2
30	828333	Gear, Pinion
31	63617	Bearing, Elevating Shaft
32	60080	* Washer, .515 x .875 x .032
33	805641-4	* Ring, Retaining 1/2
34	828331	Shaft, Elevating Crank
35	30442	Ring Retaining
36	63435	Bushing
37	102570	* Screw, Soc. Set 1/4-20 x 3/8
38	827918	Crank, Elevating
39	828233	Base Asm.
40	818199	Channel, Table Mounting
41	805553-24	* Washer, 11 /32 x 7/8 x 1/16
42	131201	* Lockwasher, 5/16
43	109163	* Bolt, Square Hd 5/16-18 x 3/4

\* Standard Hardware Item - May Be Purchased Locally

### PARTS LIST FOR RIDGID 10" RADIAL SAW MODEL NUMBER RS10000

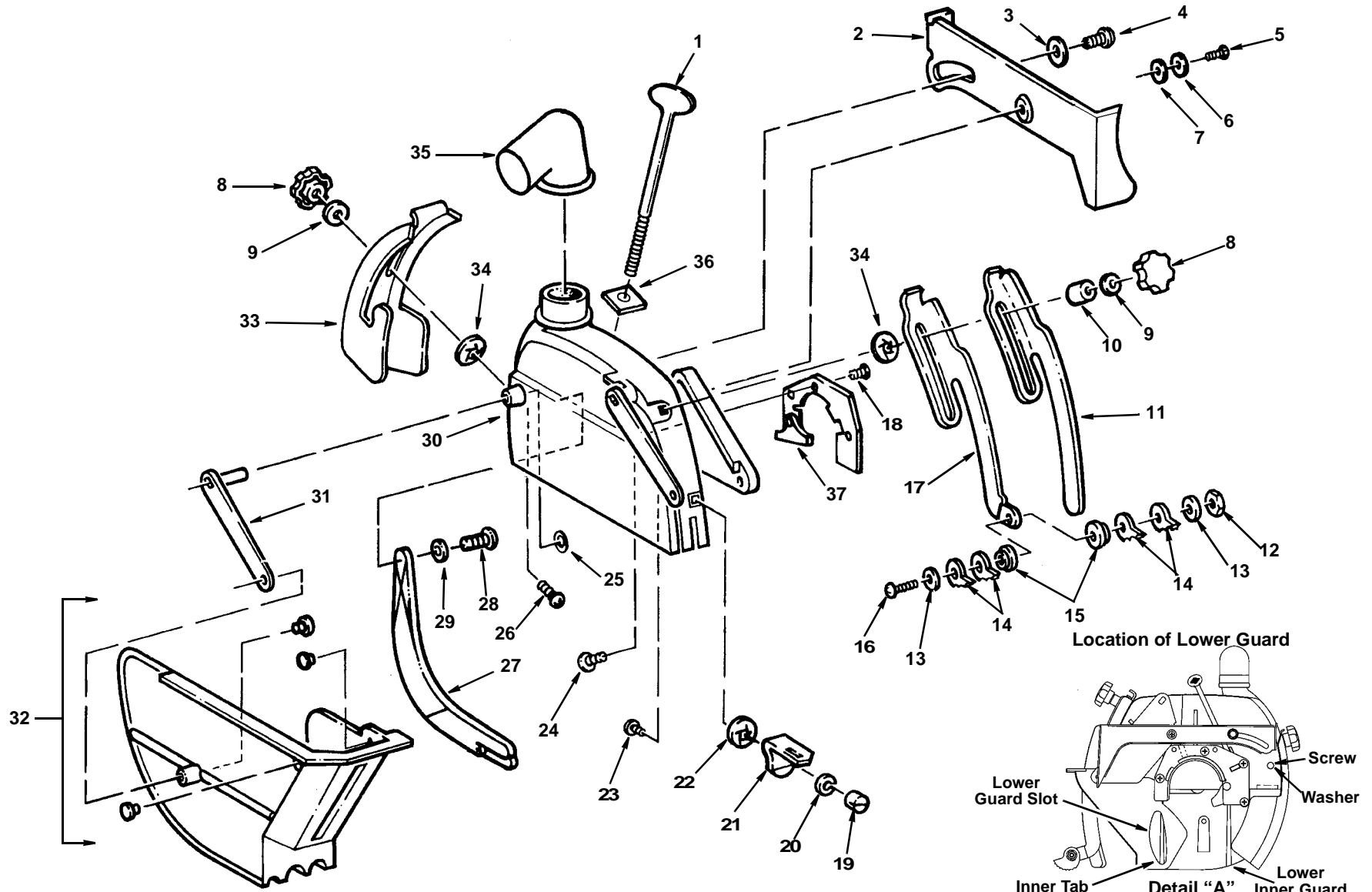

Figure 4

**PARTS LIST FOR RIDGID 10" RADIAL SAW  
MODEL NUMBER RS10000**

**Always order by Part Number - Not by Key Number**

**Figure 4 - Guard**

Key No	Part No.	Description
1	821217	Screw, Guard Clamp
2	827948	Link, Pull
3	805552	* Washer, 17/64 x 5/8 x 1/16
4	815865	Screw, Hex Washer Hd Type "TT" 1/4 - 20 x 1/2
5	816333-6	* Screw, Pan Hd Type "TT" 10-32 x 5/16
6	802392-47	Spacer #10 x .125
7	808447-6	Washer, Spring
8	827919	Knob, 5/16-18
9	274865	* Washer 21/64 x 5/8 x 1/16
10	820521	Spacer
11	820515	Knife, Riving
12	161255-6	* Nut, Lock 1/4-20
13	805552	* Washer 17/64 x 5/8 x 1/16
14	815815	Pawl, AKB
15	820517	Bushing
16	809491-1	* Screw, Pan Hd. 1/4-20 x 1
17	820512	Holder, AKB
18	824159	Screw, Flat Hd Type "TT" 1/4 - 20 x 9/16

Key No.	Part No.	Description
19	820519	Nut, Slotted 1/4 - 20
20	114604	* Lockwasher 1/4
21	820530	Support, Knife
22	808822-1	Nut, Push 1/4
23	820532	Bolt
24	809019-4	Bolt, Rd Hd Short Neck 5/16 - 18 x 1-3/4
25	820632-3	* Ring, Retaining
26	809019-5	* Bolt, R.H. Short Neck 5/16 - 18 x 5/8
27	820985	Lower, Inner Guard
28	808380	Screw Plastite #8-16 x 1/2
29	805548-10	Washer 3/16
30	824161-1	Guard
31	820524-1	Link
32	820531	Guard, Lower
33	821218-1	Hold Down
34	60413	Nut, Push 5/16
35	828139	Elbow, Dust
36	821449	Nut, Square 5/16 - 18 Double
37	827916	Strap-Retainer

\* Standard Hardware Item - May Be Purchased Locally

# Repair Parts

## PARTS LIST FOR RIDGID 10" RADIAL SAW MODEL NUMBER RS10000

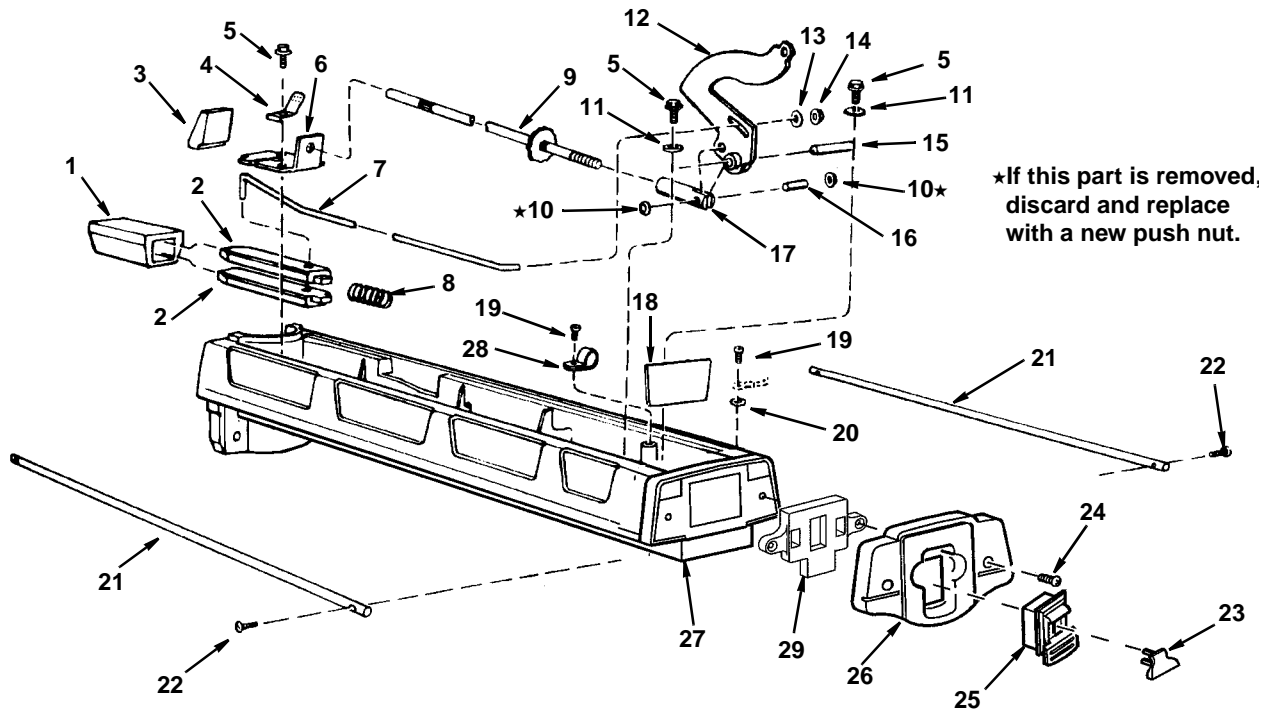

Figure 5 - Arm Assembly

Always order by Part Number - Not by Key Number

Key No.	Part No.	Description	Key No.	Part No.	Description
1	63626	Housing, Pin	17	63636	Pin, Clevis
2	63629	Pin, Arm Lock	18	63773	Insulation
3	63631	Pawl, Arm Lock	19	13848	* Screw, Type 'T' Pan Hd 10-32 x 1/2
4	63628	Spring, Tension	20	114603	* Lockwasher, Ext. Tooth N10
5	9420417	* Screw, Type "T" Hex Washer Hd 1/4-20 x 5/8	21	805840	Track
6	63883	Guide	22	448337	Screw, Type 'T' Rd. Hd 10-32 x 5/8
7	63632	Rod, Index	23	826122	Key Switch
8	63630	Spring, Arm Lock	24	60337	* Screw, Type 'T' Pan Hd 10-32 x 7/8
9	805814	Rod, Arm Lock	25	826123	Switch, Locking (Includes Key No. 23)
10	802612-8	* Nut, Push 3/8	26	827882	Cap, Arm
11	60332	* Washer, 21/64 x 1 x 1/8	27	827637	Arm, Radial
12	827881	Lever, Arm Lock	28	810659	Clamp, Cord
13	805552-7	* Washer, 17/64 x 5/8 x 1/32	29	827883	Retainer Switch
14	802612-6	* Nut, Push 1/4			
15	63638	Pin, Lever			
16	63637	Pin			

\* Standard Hardware Item - May Be Purchased Locally

## PARTS LIST FOR RIDGID 10" RADIAL SAW MODEL NUMBER RS10000

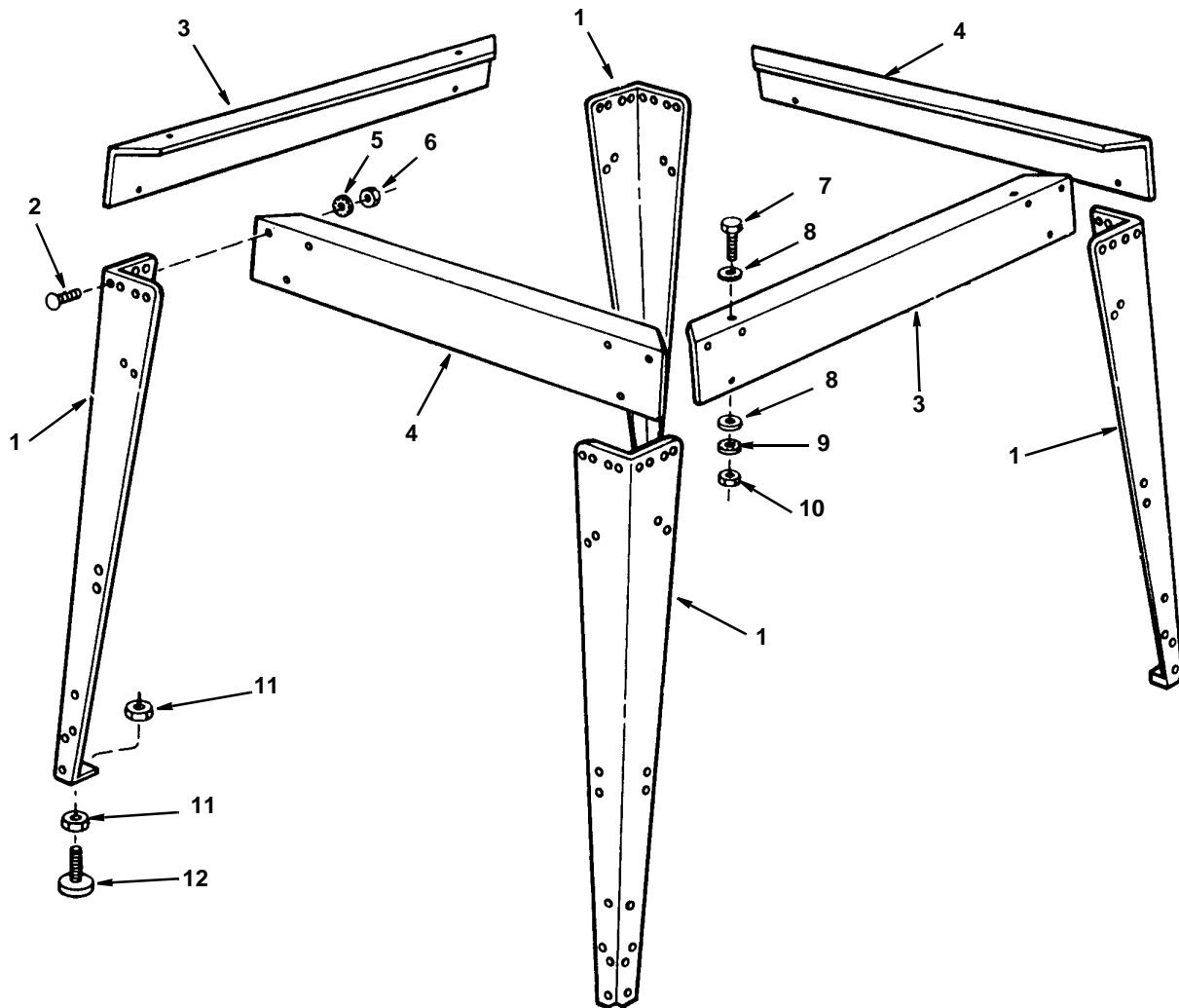
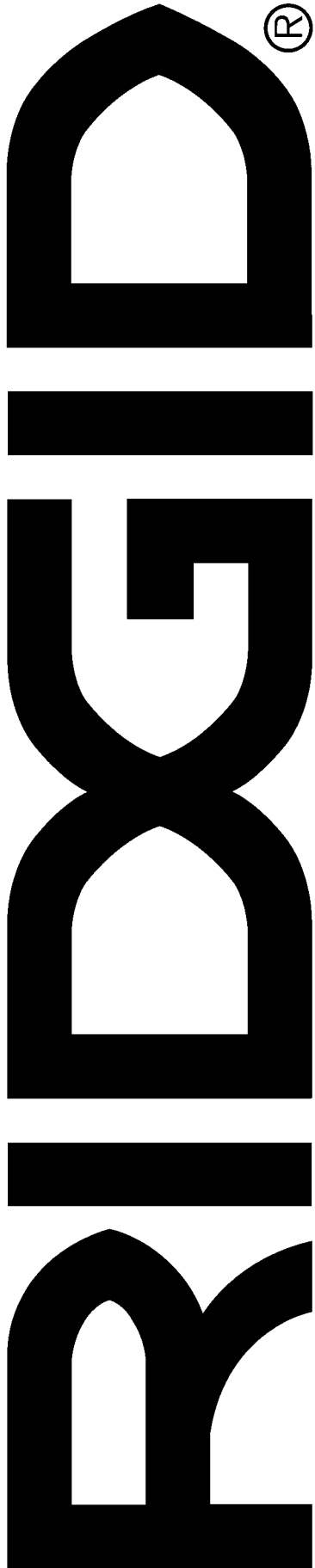

**Figure 6 - Leg Set**

**Always order by Part Number - Not by Key Number**

Key No.	Part No.	Description	Key No.	Part No.	Description
1	821343-1	Leg	8	118774	* Washer, 11 /32 x 11 /16 x 1/16
2	805589-5	Screw, Truss Hd. 1/4-20 X 1/2	9	131201	* Lockwasher, External 5/16
3	821779-1	Stiffener, Side	10	805482	* Nut, Hex Jam 5/16-18
4	821780-1	Stiffener, Front/Rear	11	118645	* Nut, Hex 3/8-16
5	114604	* Lockwasher, External 1/4	12	803835-3	Foot, Leveling
6	115120	* Nut, Hex 1/4-20			
7	805467-3	Screw, Hex Hd 5/16-18 x 5/8			

\* Standard Hardware Item - May Be Purchased Locally



## Lifetime Warranty On RIDGID Tools

The RIDGID REPUTATION is the result of the consistent product quality and years of pride in workmanship. Rigorous checks and controls from raw materials to packaged products insure product confidence widely accepted as the mark of the professional trades. Therefore, RIDGID covers its products with a LIFETIME WARRANTY against defects in material or workmanship. To take advantage of this warranty, the complete product must be delivered prepaid to any RIDGID AUTHORIZED SERVICE CENTER. Obviously, failures due to misuse, abuse or normal wear and tear are not covered by this warranty. NO OTHER WARRANTY, WRITTEN OR ORAL, APPLIES. No employee, agent, dealer or other person is authorized to give any warranty on behalf of RIDGID Power Tools, Emerson Electric Co. Warranted products will be repaired or replaced, at our option, at no charge to you and returned to you via prepaid transportation. Such replacement or repair is the exclusive remedy available from RIDGID Power Tools, Emerson Electric Co. Emerson Electric Co. is not liable for damage of any sort, including incidental and consequential damages. Some U.S.A. states do not allow the exclusion or limitation of incidental or consequential damages, so the above limitation or exclusion may not apply. This warranty gives you specific legal rights, and you may have other rights which vary from state to state.

**Stock No. RS1000**

**Model No. RS1000 0**

The model and serial number of your Radial Saw may be found at the front of the base.

You should record both model and serial number in a safe place for future use.

**QUESTIONS OR COMMENTS?**

**CALL 1-800-4-RIDGID**

© 2000 Emerson Electric Co.



**RIDGID Power Tools**  
**Emerson Electric Co.**