



MK CX-3

GAS POWERED CONCRETE SAW OWNER'S MANUAL & OPERATING INSTRUCTIONS



CAUTION:
Read all safety and
operating instructions
before using this
equipment

Enter the Serial Number of your new saw in the
space below. The Serial Number is located on the
Rear Crossbar

SERIAL NUMBER:

NOTE:

For your (1) one year warranty to be effective
complete the warranty card (including the Serial
Number) and mail it in as soon as possible.

EXPLODED VIEW AND PARTS LIST

EXPLODED VIEW:

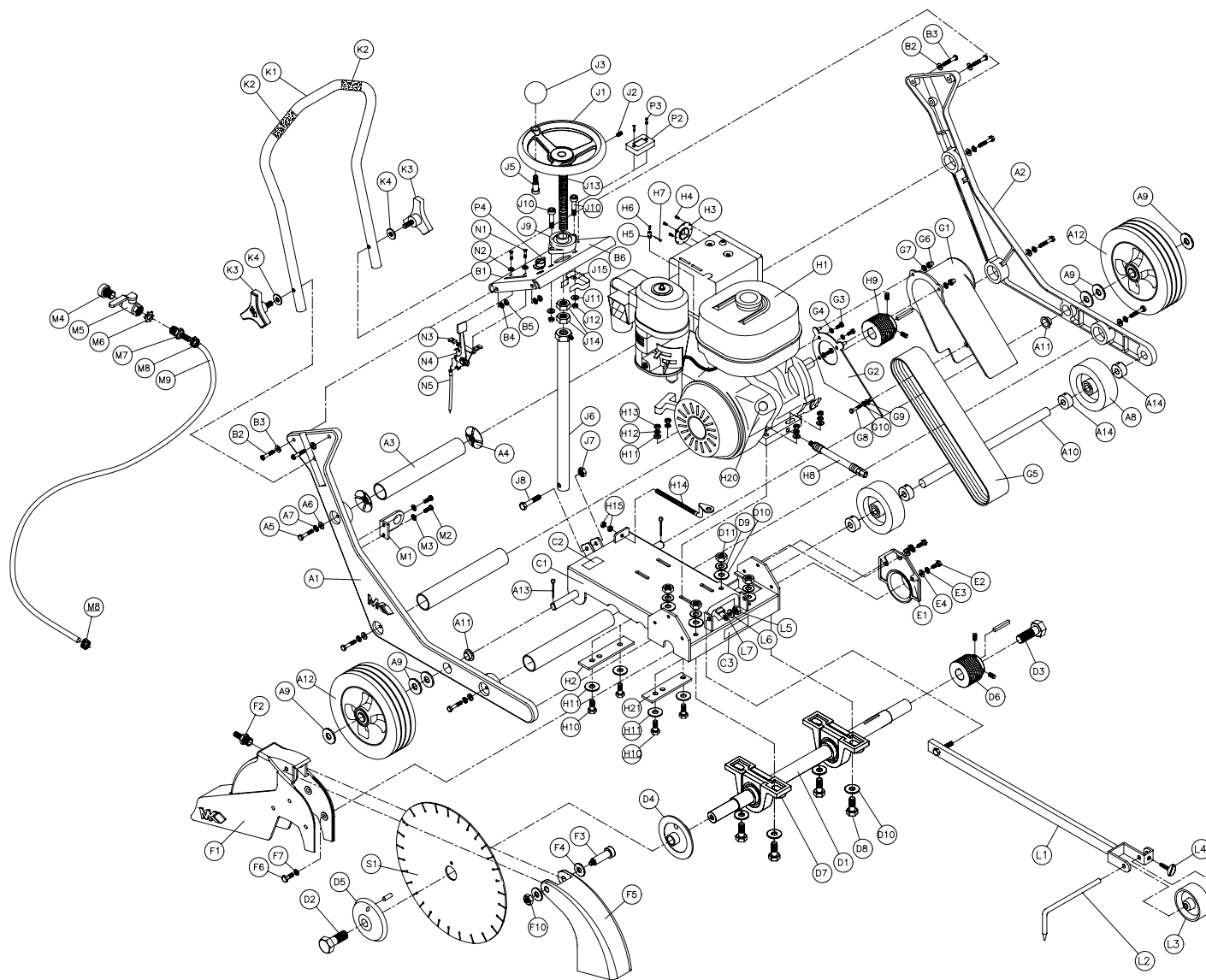

EXPLODED VIEW AND PARTS LIST

PARTS LIST:

Item	Description	Qty	MK p/n
A	Assembly, Frame	1	n/a
A1	Casting, Frame, Right	1	159257
A2	Casting, Frame, Left	1	159259
A3	Support, Horizontal Frame	3	158857
A4	Connector, Tube Ø1 3/8 x 5/16-18	6	159206
A5	Screw, 5/16-18 x 1 ½ Hex Hd. Cap	6	152467
A6	Washer, 5/16 SAE Flat	6	151754
A7	Washer, 5/16 Split Lock	6	151747
A8	Wheel, Front, 4 X 1 ½	2	150830
A9	Shim, ¾ x 1 ¼ x .045	6	153699
A10	Axle, Front	1	158862
A11	Bushing, Flange	2	159207
A12	Wheel, Rear, 8 X 2 ¼	2	155986
A13	Pin, Cotter 1/8 x 1.0	4	156613
A14	Collar, Set ¾	4	153814
B	Assembly, Console	1	n/a
B1	Console, Frame	1	158828
B2	Screw, 5/16-18 x 1 ½, Hex Head Cap	4	152467
B3	Washer, 5/16 SAE Flat	4	151754
B4	Washer, 5/16 Split Lock	4	151747
B5	Nut, 5/16 Hex	4	101196
B6	Label, Console	1	159208
C	Assembly, Truck	1	n/a
C1	Truck, Weldment	1	159260
C2	Plate, Serial Number	1	157918
C3	Label, CX3	1	159482
C4	Tag, Serial Number, Blank	1	157500
D	Assembly, Blade Shaft	1	n/a
D1	Shaft, Blade,	1	158879
D2	Screw, Blade Shaft, ½-13 x 1 Hex Head, Left Hand Thread, Grade 5	1	159203
D3	Screw, Blade Shaft, ½-13 x 1 Hex Head, Right Hand Thread, Grade 5	1	159204
D4	Flange, Inner	1	158880
D5	Flange, Outer	1	158881
D6	Pulley, Polly-V 2 ½ x 1 x J16	1	158470
D7	Bearing, 1" Pillow Block	2	155072
D8	Screw, 3/8-16 X 1 1/2 Hex Head Cap	4	153528
D9	Washer, 3/8 Split Lock	4	150925
D10	Washer, 3/8 SAE Flat	8	101360
D11	Nut, 3/8-16 Hex	4	101188
E	Assembly, Shaft Cover	1	n/a
E1	Casting, Cover, Shaft	1	158843
E2	Screw, 5/16-18 X 1 Hex Head Cap	3	151743
E3	Washer, 5/16 Split Lock	3	151747
E4	Washer, 5/16 SAE Flat	3	151754

EXPLODED VIEW AND PARTS LIST

F	Assembly, Blade Guard	1	n/a
F1	Guard, DC Rear Blade	1	159262DC
F2	Fitting, Brass, 1/8 MNPT X 3/8 BARB	1	152501
F3	Screw, 3/8 X 2 1/2 Socket Head Shoulder, w/ 5/16-18 Thread	1	160492
F4	Washer, 3/8 SAE Flat	2	150923
F5	Guard, DC Front Blade	1	158951DC
F6	Screw, 5/16-18 x 3/4 Hex Head Cap	3	151369
F7	Washer, 5/16 Split Lock	3	151747
F8	Label, Caution, Lift Guard, 1.5 X 3.0	1	155586
F9	Label, Warning, Blade Failure, 1.5 X 3.0	1	155588
F10	Nut, 5/16-18 Nylock Hex	1	151746
G	Assembly, Belt Guard	1	n/a
G1	Casting, Guard, Belt	1	159021
G2	Guard, Inner Belt	1	159250
G3	Screw, 5/16-24 UNF X 1/2 Hex Head Cap	3	159205
G4	Washer, 5/16 Split Lock	3	151747
G5	Belt, Polly-V, 240J16	1	158824
G6	Nut, 1/4-20 Acorn, High Crown	2	159464
G7	Washer, 1/4 Split Lock	2	152591
G8	Screw, 1/4-20 x 1/2 Hex Head Cap	1	152608
G9	Washer, 1/4 SAE Flat	3	151915
G10	Washer, 1/4 Split Lock	3	152591
G11	Label, Caution, Guards in Place, 1.5 x 3.0	1	155587
H	Assembly, Honda 6.5 H.P. Engine		n/a
H1	Honda GX200QXC9 6.5 hp w/ Cyclone Filter	1	159347
H2	Plate, Engine Bolt	1	157847
H3	Deflector, 8 hp	1	155375
H4	Screw, 6-32 x 1/2 Pan Head Phillips Self-Tapping Cap	3	153466
H5	Pin, Throttle Control	1	151284
H6	Screw, 8-32 x 3/8 Pan Head Cap	1	156614
H7	Pin, Cotter, 1/16 x 3/4	1	152518
H8	Oil Drain, Sub-assembly	1	157577-01
H9	Pulley, Polly-V, J16 x 2 1/2 x 1.0 I.D.	1	158959
H10	Screw, 5/16-18 x 2 Hex Head Cap	4	155494
H11	Washer, 3/8 SAE Flat	7	150923
H12	Washer, 3/8 Split Lock	4	150925
H13	Nut, 3/8-16 Hex	4	101188
H14	Arm, Tension	1	157848
H15	Nut, 5/16-18	2	101196
H16	Label, Caution, Hot Surface 1.5 x 3.0	1	155578
H17	Label, Warning, Refueling, 1.5 x 3.0	1	155580
H18	Label, Danger, California, 1.5 x 3.0	1	155581
H19	Label, Danger, Lethal Exhaust, 1.5 x 3.0	1	155582
H20	Plug, Plastic, 3/4 Round	1	156615
H21	Plate, Engine Bolt, Front	1	159868
H22	Label, Home Depot Tool Rental	1	160602
H23	Label, Caution Belt Tension, 1.5 x 3.0	1	155583
H24	Label, Caution, Sparkplug, 1.5 x 3.0	1	155579
H25	Label, Caution, Hands and Feet, 2 X 4	1	155585

EXPLODED VIEW AND PARTS LIST

J	Assembly, Depth Control	1	N/a
J1	Wheel, Depth Control	1	155156
J2	Screw, 3/8-16 X 1/2 Socket Head Set	1	153710
J3	Knob, Ball, 2", 3/8-16 Insert	1	158519
J5	Screw, 1/2 X 3/4 Socket Head Shoulder, w/ 3/8-16 X 5/8 Thread	1	156177
J6	Tube, Depth Control 3/4-10	1	159098
J7	Nut, 3/8-16 Nylock Hex	1	152505
J8	Screw, 3/8-16 X 2 Hex Head Cap	1	153485
J9	Bearing, Flange, FHSLF 204-12G	1	155151
J10	Screw, 3/8-16 X 1 1/2 Hex Head Cap	2	153528
J11	Washer, 3/8 SAE Flat	2	151915
J12	Nut, 3/8-16 Nylock Hex	2	152505
J13	Screw, Depth Control	1	155062
J14	Nut, 3/4-10 Hex	2	155063
J15	Spring, Detent	1	156609
K	Assembly, Handlebar	1	n/a
K1	Handlebar	1	158849
K2	Grip, Handle	2	229413
K3	Tri-Knob, 3/8-16 X 2	2	156770-04
K4	Washer, 3/8 SAE Flat	4	150923
L	Assembly, Pointer	1	155568
L1	Arm, Pointer	1	155056
L2	Pointer	1	155057
L3	Wheel, Pointer, w/ 3/8 X 1/2 X 1 5/8 nylon bushing	1	155066
L4	Screw, 1/4-20 X 3/4 Thumb	2	150991
L5	Nut, 3/8-16 Nylock Hex	3	152505
L6	Washer, 3/8 SAE Flat	1	150923
L7	Clip, Stop	1	157837
M	Assembly, Water Valve	1	155458
M1	Bracket, Water Valve	1	158833
M1A	Bracket, Water Valve	1	158833-OR
M2	Screw, 1/4-20 x 1/2 Hex Head Cap	2	152608
M3	Washer, 1/4 Split Lock	2	152591
M4	Fitting, Brass, 1/2 MNPT X Garden Hose Swivel	1	151322
M5	Valve, Ball, Shut-Off, 1/2 FNPT X 1/2 FNPT	1	150843
M6	Nut, 1/2 NPT	1	152729
M7	Fitting, Brass, 1/2 MNPT X 3/8 BARB	1	153653
M8	Clamp, 5/8 Hose	2	151198
M9	Hose, 3/8 ID Vinyl	30"	150845
N	Assembly, Throttle, Honda	1	n/a
N1	Screw, 10-24 X 1/2 Pan Head Phillips Cap	2	151744
N2	Washer, #10 SAE Flat	2	154369
N3	Nut, 10-24 Clip	2	155407
N4	Assembly, Throttle Control	1	155406
N5	Cable, Throttle, CX3 Honda	1	159479
NA	Assembly, Throttle, Robin	1	n/a
NA1	Screw, 10-24 X 1/2 Pan Head Phillips Cap	2	151744
NA2	Washer, #10 SAE Flat	2	154369

EXPLODED VIEW AND PARTS LIST

NA3	Nut, 10-24 Clip	2	155407
NA4	Assembly, Throttle Control	1	155406
NA5	Cable, Throttle, CX3 Robin	1	159495
P	Assembly, Wire Harness, CX3 Premium	1	n/a
P1	Harness, Wire, CX3 Premium	1	159480
P2	Tachometer (redington)	1	159477
P3	Screw, 6-32 x 3/8, Pan Head Self Tapping	2	153466
P4	Switch, Engine On/Off	1	157851
PA	Assembly, Wire Harness, Standard	1	n/a
PA1	Harness, Wire, Standard	1	158232
PA2	Switch, Engine On/Off	1	157851
Q	Assembly, Accessory Pack,	1	n/a
Q1	Manual, Owner's	1	159348
Q2	Card, Warranty	1	155859
Q3	Tube, Owner's Manual	1	155419
Q4	Wrench, 3/4, Open End	2	159476
R	Assembly, Carton		159349
R1	Carton, Outer	1	159349-01
R2	Carton, Top Pad	1	159349-02
R3	Carton, Tray	1	159349-03
R4	Carton, Chock	1	159349-04
R5	Carton, Accessory Box	1	159349-05
R6	Carton, Bumper	1	159349-06
S	Blades	-	-
S1	MK-CX10, 12 x .100 x 1.0	1	159615-CX
S2	MK-CX10, 14 x .100 x 1.0	1	159616
S3	MK-AX10, 12 x .100 x 1.0	1	159617
S4	MK-AX10, 14 x .100 x 1.0	1	159618
S5	MK-GX10, 12 x .100 x 1.0	1	159619
S6	MK-GX10, 14 x .100 x 1.0	1	159620