

0 601 913 260



Stand  05-03-23
Issue 

Fig./Abb. 1



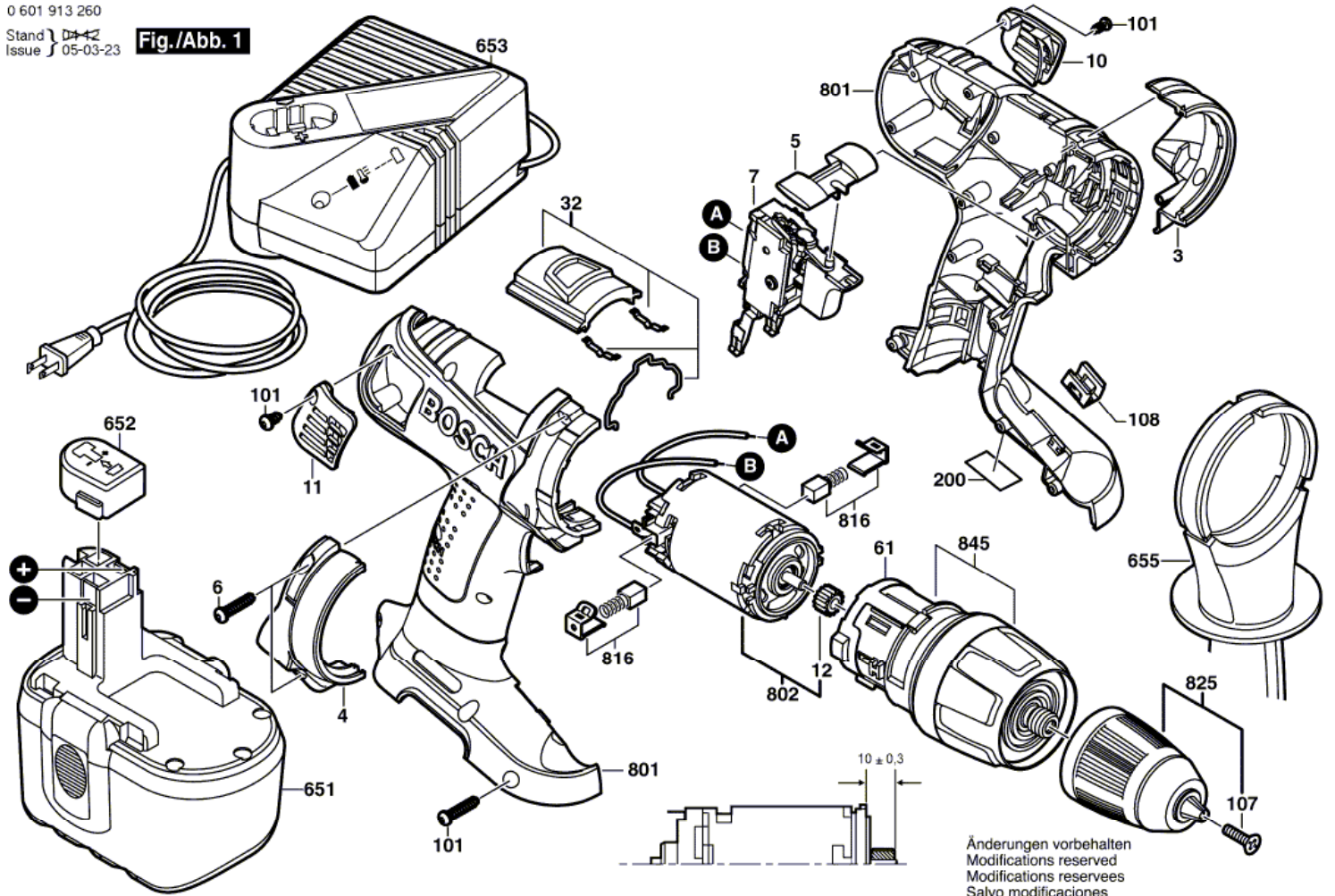

Pos.	Part Number	Description	Pos.	Part Number	Description
3	2 605 500 168	PROTECTIVE CAP			
4	2 605 500 169	PROTECTIVE CAP			
5	2 601 099 112	ADJUSTING SLIDE			
6	2 603 410 052	THREAD-FORMING TAP. SCREW			
7	2 607 200 458	ON-OFF SWITCH			
10	2 600 508 051	COVER			
11	2 600 508 052	COVER			
12	2 606 316 222	PINION			
32	2 601 099 127	ADJUSTING SLIDE			
61	2 608 040 190	SUPPORT			
101	2 603 490 018	TORX OVAL-HEAD SCREW			
107	2 603 421 229	COUNTERSUNK-HEAD SCREW			
108	2 604 690 027	SPRING ELEMENT			
200	2 601 116 994	REFERENCE PLATE			
651	2 607 335 451	SLIDE-IN ACCU PACKAGE			
652	2 609 100 101	COVER			
653	2 607 225 033	BATTERY CHARGER			
655	2 602 025 126	AUXILIARY HANDLE			
801	2 605 105 928	HOUSING SECTION			
802	2 607 022 855	DC MOTOR			
816	2 607 034 901	CARBON-BRUSH SET			
825	2 608 572 900	KEYLESS CHUCK			
845	2 606 200 937	EPICYCLOIDAL GEAR TRAIN			