



SERVICE PARTS LIST

BULLETIN NO.
54-06-1375

SPECIFY CATALOG NO. AND SERIAL NO. WHEN ORDERING PARTS		REVISED BULLETIN	DATE
2.4 VOLT CAULK GUN			Sept. '98
CATALOG NO.	6550-20	SERIAL NUMBER	961031
		WIRING INSTRUCTION 58-01-0005	

00 0

EXAMPLE:
Component Parts (Small #) Are Included
When Ordering The Assembly (Large #).

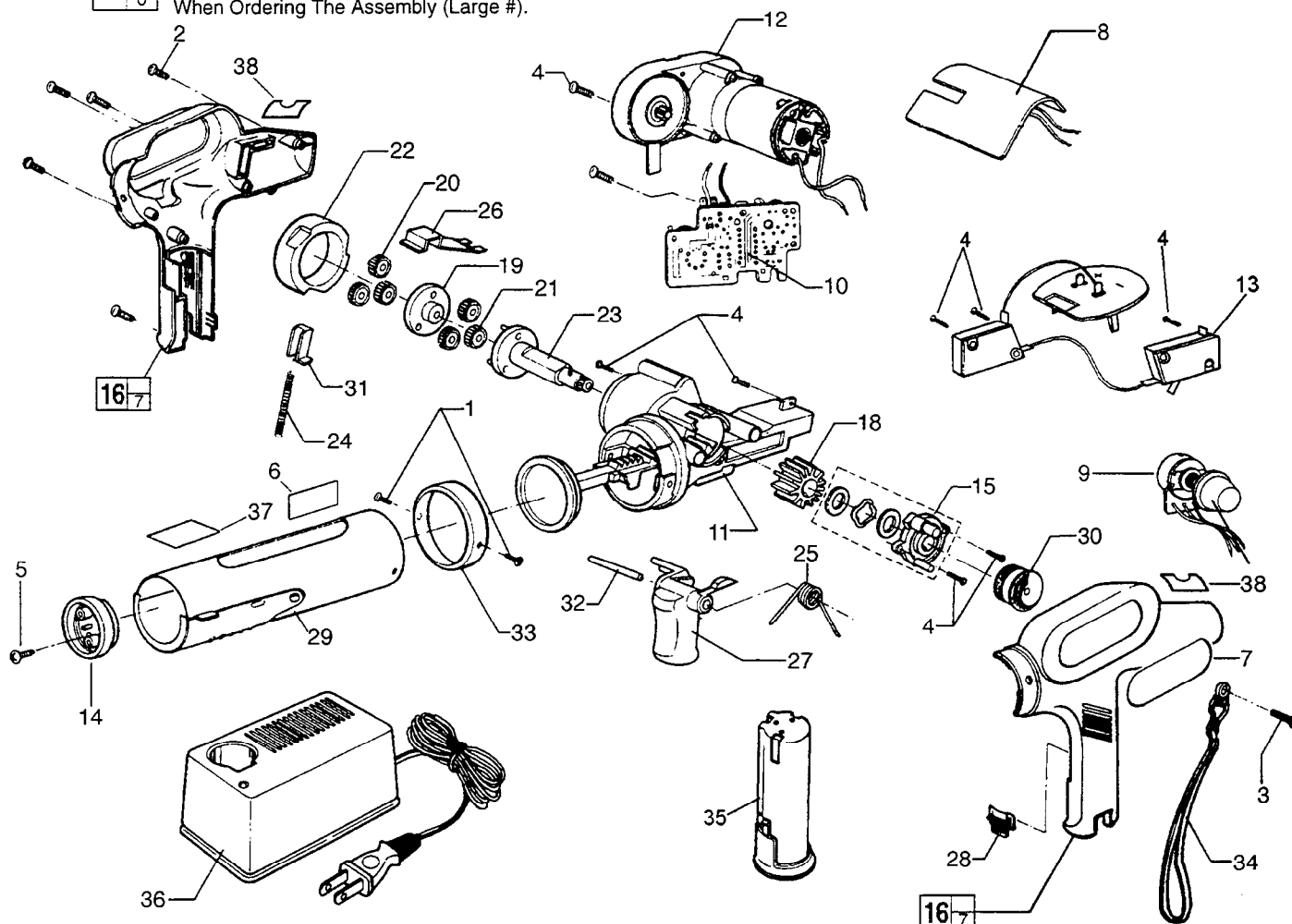

FIG.	PART NO.	DESCRIPTION OF PART	QTY.
1	05-78-0755	Screw	2
2	05-78-0760	Screw	5
3	05-78-0765	Screw	1
4	05-78-0770	Screw	8
5	05-81-0990	Screw	1
6	10-15-0182	Label	1
7	12-45-6550	Nameplate	1
8	14-20-3085	FET Assembly	1
9	14-20-3090	Speed Dial Assembly	1
10	14-20-3095	Speed Control Module	1
11	14-50-0680	Drive Assembly	1
12	14-50-0685	Motor Assembly	1
13	23-66-2555	Switch Assembly	1
14	31-12-0295	Cap	1
15	31-15-0545	Housing Cover	1
16	31-44-2110	Handle Halves	1
18	32-60-2650	Pinion Gear	1
19	32-60-2655	Gear	1
20	32-62-0093	Planet Gear	3
21	32-62-0095	Gear	3
22	32-65-0085	Ring Gear	1
23	36-18-0580	Drive Shaft	1
24	40-50-8915	Spring	1
25	40-50-8920	Spring	1

FIG.	PART NO.	DESCRIPTION OF PART	QTY.
26	40-50-8925	Spring	1
27	42-42-0480	Switch Button	1
28	42-42-0485	Lock Button	1
29	43-72-0255	Tube Holder	1
30	43-82-0155	Indicator	1
31	43-96-0235	Key	1
32	44-60-1525	Pin	1
33	44-90-4520	Ring	1
34	45-56-2625	Wrist Strap	1
35	48-11-0100	Battery 2.4 Volt	1
36	48-59-0182	Battery Charger 2.4 Volt	1
37	10-15-0183	Warning Label	1
38	10-15-0184	Speed Control Label	1

FIG. LUBRICATION

- 11 Coat gear portion of drive assembly with a thin coat of Type "E" grease, No. 49-08-4122.
- 18-23 Apply a thin coat of Type "E" grease, No. 49-08-4122, to gears and drive shaft.

MILWAUKEE ELECTRIC TOOL CORPORATION
13135 W. LISBON RD., BROOKFIELD, WI 53005