



SERVICE PARTS LIST

BULLETIN NO.
54-40-0230

SPECIFY CATALOG NO. AND SERIAL NO. WHEN ORDERING PARTS		REVISED BULLETIN	DATE
14" CHOP SAW			Oct. '87
CATALOG NO. 6170	STARTING SERIAL NO. 594-1001	WIRING INSTRUCTION SEE REVERSE SIDE	

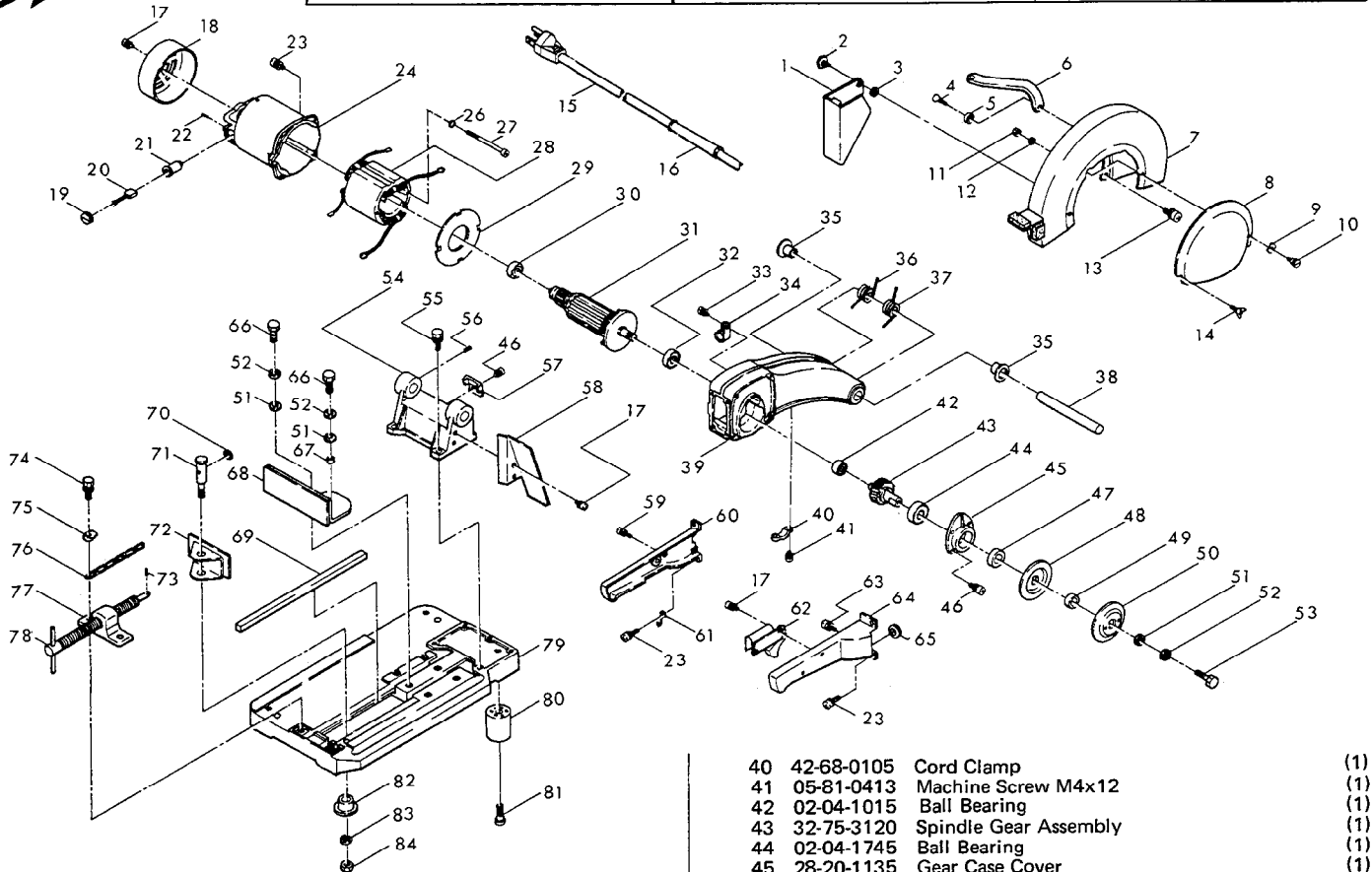

FIG.	PART NO.	DESCRIPTION OF PART	NO. REQ.
1	43-54-0470	Front Guard	(1)
2	05-77-0250	Guard Bolt	(1)
3	45-88-7890	Nylon Washer	(1)
4	05-81-0700	Machine Screw M6x16	(2)
5	45-88-7895	Washer	(2)
6	45-56-0180	Carrying Handle	(1)
7	43-54-0480	Wheel Guard	(1)
8	42-92-0500	Wheel Guard Cover	(1)
9	45-88-0585	Wave Washer	(1)
10	05-77-1050	Bolt M4	(1)
11	05-55-0003	Nut M4 (Includes Fig. No. 12)	(1)
12	—	Spring Washer	(1)
13	05-81-0710	Screw M6x16	(4)
14	05-77-0550	Wing Screw M5x10	(1)
15	22-64-4465	Cord Set	(1)
16	44-76-0140	Cord Protector	(1)
17	05-78-0450	Machine Screw M4x8	(6)
18	42-92-0510	Motor End Cover	(1)
19	22-24-0270	Brush Holder Cap	(2)
20	22-16-0310	Carbon Brush	(2)
21	22-20-0460	Brush Holder	(2)
22	05-81-0480	Screw M5x10	(2)
23	05-81-0750	Machine Screw M6x20	(8)
24	31-50-0440	Motor Housing	(1)
26	45-88-0708	Spring Washer	(2)
27	05-81-0675	Field Screw M5x88	(2)
28	18-82-1240	Field	(1)
29	42-14-0280	Air Baffle	(1)
30	02-04-1050	Ball Bearing	(1)
31	16-82-1850	Armature Assembly (Incl. Fig. No. 30)	(1)
32	02-04-1535	Ball Bearing	(1)
33	05-81-0475	Machine Screw	(1)
34	43-72-0110	Cord Holder	(1)
35	42-40-0680	Nylon Bushing	(2)
36	40-50-0970	Left Torsion Spring	(1)
37	40-50-0980	Right Torsion Spring	(1)
38	06-65-1800	Hinge Pin	(1)
39	31-40-0050	Gear Case	(1)

40	42-68-0105	Cord Clamp	(1)
41	05-81-0413	Machine Screw M4x12	(1)
42	02-04-1015	Ball Bearing	(1)
43	32-75-3120	Spindle Gear Assembly	(1)
44	02-04-1745	Ball Bearing	(1)
45	28-20-1135	Gear Case Cover	(1)
46	05-81-0500	Screw M5x16	(6)
47	42-76-0320	Spindle Collar	(1)
48	43-34-0520	Inside Flange	(1)
49	42-76-0340	Wheel Collar	(1)
50	43-34-0530	Outside Flange	(1)
51	45-88-5375	Flat Washer	(3)
52	05-90-0175	Lock Washer	(3)
53	05-77-2500	Bolt M10x1.25x22	(1)
54	42-36-1470	Hinge Bracket	(1)
55	05-77-1600	Bolt M6x20	(5)
56	05-86-0590	Allen Hd. Set Screw M6x8	(1)
57	45-52-2020	Stop	(1)
58	45-12-0350	Spark Shield	(1)
59	05-81-0420	Screw M4x20	(4)
60	31-44-1280	Left Handle Half	(1)
61	43-74-0100	Hook	(1)
62	23-66-1320	Switch	(1)
63	05-81-0400	Screw M4x6	(1)
64	31-44-1275	Right Handle Half	(1)
65	42-40-0685	Bushing	(1)
66	05-77-2520	Bolt M10x1.25x25	(2)
67	42-76-0330	Vise Pivot Collar	(1)
68	42-68-0480	Fixed Vise	(1)
69	30-37-0030	Vise Guide	(2)
70	45-88-0715	Washer	(1)
71	06-65-1910	Vise Pin	(1)
72	42-68-0490	Moveable Vise	(1)
73	06-65-1680	Roll Pin	(1)
74	05-77-1800	Bolt M8x25	(2)
75	43-72-0120	Chain Holder	(1)
76	42-60-0150	Link Chain	(1)
77	44-40-0585	Vise Screw Nut	(1)
78	45-04-0640	Vise Screw	(1)
79	31-06-0080	Base	(1)
80	44-34-0140	Rubber Mount	(4)
81	05-81-0900	Machine Screw M8x30	(4)
82	42-76-0350	Collar	(1)
83	05-90-0200	Lock Washer	(1)
84	05-55-1500	Nut M12	(1)

MILWAUKEE ELECTRIC TOOL CORPORATION
13135 W. LISBON RD., BROOKFIELD, WIS. 53005

CIRCUIT DIAGRAM

