

SPECIFY CATALOG NO. AND SERIAL NO. WHEN ORDERING PARTS		REVISED BULLETIN	DATE
3.5 H.P. ROUTER			Oct. 2007
CATALOG NO. 5625-20/5625-29	SERIAL NUMBER 395A	WIRING INSTRUCTION 58-01-0716	

FIG.	PART NO.	DESCRIPTION OF PART	QTY.
1	02-04-0852	Ball Bearing	(1)
2	02-04-2006	Ball Bearing	(1)
3	06-81-0025	5/16-18 x .625 Machine Screw	(4)
4	06-82-5338	1/4-20 x .50 Slit. Pan Hd. Tapt. T-30	(4)
5	06-82-5514	1/4-20 x 1.50" Slit. Pan Hd. Tapt. T-30	(1)
6	06-82-5574	10-24 x .875" Pan Hd. Slit. Tapt. T-25	(5)
7	06-82-7270	8-16 x .625" Pan Hd. Slit. Plast. T-20	(7)
8	06-82-7455	8-16 x 2.38" Pan Hd. Slit. Plast. T-20	(2)
9	06-82-8865	10-32 x .43" Pan Hd. Tapt. Sems T-25	(2)
10	10-25-0010	Dial Position Label	(1)
11	12-25-0355	Nameplate	(1)
12	12-20-5625	Service Nameplate Kit	(1)
13	14-20-0050	Electronic Feedback Module	(1)
14	16-70-0005	Armature	(1)
15	18-70-1005	Field	(1)
16	22-18-0075	Brush Assembly	(2)
17	22-22-0030	Brush Tube Assembly	(2)
18	22-64-0205	Cord Set Assembly	(1)
19	23-16-0415	Field Insulator	(1)
20	23-38-0200	Tachometer	(1)
21	23-66-2280	Rocker Switch	(1)
22	23-94-0030	Leadwire Assembly	(1)
23	26-06-0105	Base	(1)
24	28-50-0110	Motor Housing	(1)
25	31-01-0025	Depth Scale	(1)
26	49-54-1026	Sub Base	(1)
27	31-15-0085	Motor Cover	(1)
28	31-17-0075	Cord Clamp	(1)
29	31-44-0135	Right Handle	(1)
30	31-44-0136	Left Handle	(1)
31	31-50-0120	Motor Frame	(1)
32	31-55-0015	Contamination Shield	(1)
33	40-50-4005	Compression Spring	(1)
34	42-42-0126	Release Button	(1)
35	43-98-0531	Depth Knob	(1)
36	44-10-0435	Base Clamp Lever	(1)
37	44-40-0095	Collet Nut (2 supplied with tool)	(1)
38	44-60-0095	Thru Pin	(1)
39	44-66-0035	Wear Plate	(1)
40	45-08-0030	Depth Shaft Assembly	(1)
41	45-10-0081	Collet Shank (See reverse side for servicing)	(1)
42	45-12-0015	Dust Shield	(1)
43	45-88-0045	Washer	(1)
44	44-76-0210	Cord Protector	(1)
45	22-84-0380	Fan Assembly	(1)
46	48-66-0985	1/4" Collet	(1)
46	48-66-1010	1/2" Collet	(1)
47	45-88-0577	Wave Spring Washer	(2)
	49-96-0365	1-1/8" Open End Wrench (Not Shown)	(2)

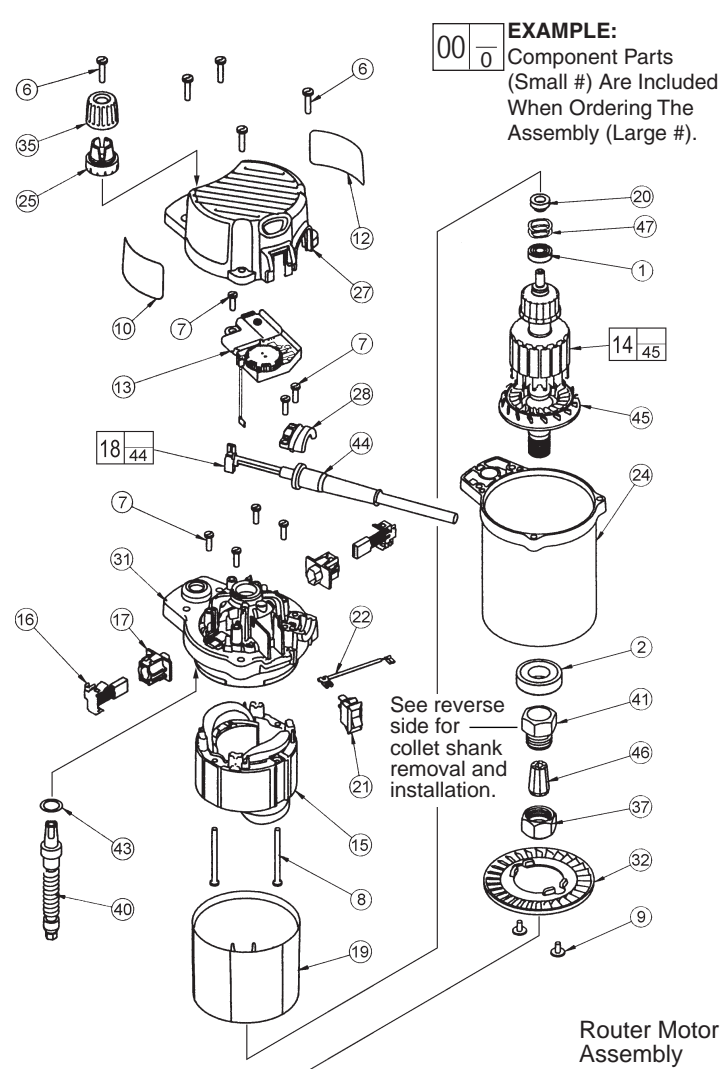
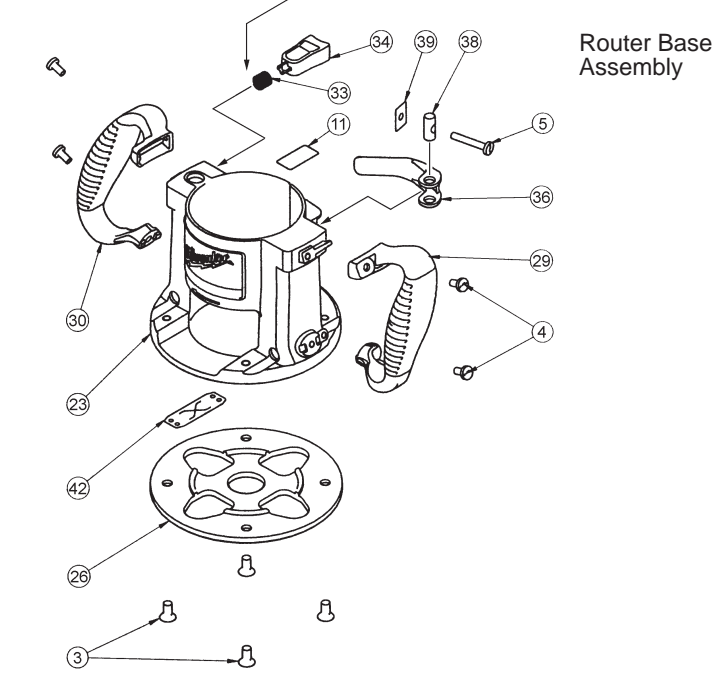

FIG. NOTES:

- 5 Apply Blue Loctite® sealant to base lever clamp screw (5). Apply to bottom 1/4" to 1/2" of screw threads.
- 14 Apply Blue Loctite® sealant to armature shaft threads (14). Apply 1 to 3 drops in the center portion of thread length area. Internal cone surface must remain free of Loctite®.
- 5,36 Clamping force for the base clamp lever (36) is adjusted with base clamp screw (5). Tighten the screw using 10-20 lbs. force to close the lever to the locked position. Motor unit must be in base when checking force.
- 23,33,34 To service the release button (34) and the compression spring (33) a long, thin tool like a flat blade screwdriver must be used. From the bottom of the base (23), insert the screwdriver into the cavity located under the release button. Press on the button detent to release.
- 36,38 Apply a thin coat of "L" grease, No. 49-08-4170, to the pivot surface areas of the base clamp lever (36). Apply a thin coat of grease to the surface of the thru pin (38).
- 41 Tighten collet shank (41) to at least 200 in-lbs. Apply Blue Loctite® sealant (Reference note on fig. 14).



45-10-0081 Collet Shank – removal / installation

(For tools with armatures shafts that do not have a 3/8" internal hex)

Removal or installation of the Collet Shank (fig. 41) for a 5625 Router can best be accomplished by using a service tool fashioned from a 1/2" drill reversing spindle, a reversing 1/2" 3 jaw chuck and a left hand reversing spindle screw. Assemble the three pieces together; secure the assembly together by applying Loctite® or an equivalent thread locking adhesive to the left hand screw. Optional, remove or cut the back end of the spindle off, as pictured below, leaving only a 11/16" hex nut.

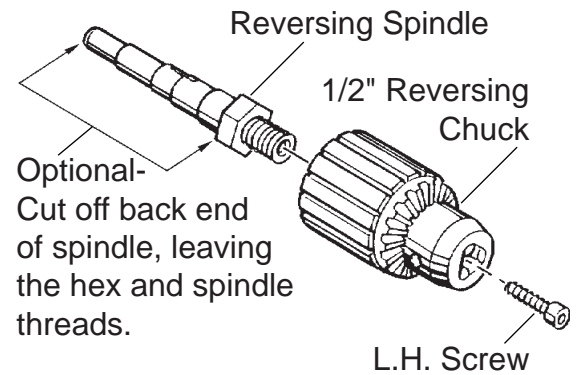

Removal of the Collet Shank from the Armature Shaft...

- Step 1** Remove the rear commutator Ball Bearing (fig. 1) from the Armature (fig. 14).
- Step 2** Attach the '3-Jaw Chuck' service tool to the armature shaft, being sure that the jaws grip the shaft beyond the ball bearing journal. The jaws of the '3 Jaw Chuck' should be in contact with the back of the armature commutator. To keep chuck jaws from spinning on the shaft, tighten, turning chuck key in all three holes of the chuck body. **CAUTION! Do not grip the rear ball bearing journal of the armature shaft.**
- Step 3** Clamp the hex of the service tool securely into a vise.
- Step 4** Use a 1-1/8" hex socket or box wrench on the hex of the collet shank. Turn the collet shank counter-clock wise to remove.



Installation of the Collet Shank to the Armature Shaft... torque specification of the Collet Shank to the armature shaft is 200 in-lbs / 16.5 ft-lbs (vigorously hand-tight)...

- Step 1** Attach the '3 Jaw Chuck' service tool to the armature shaft as described in step 2 above. Clamp the hex of the '3 Jaw Chuck' service tool into a vise.
- Step 2** Using a 1-1/8" hex socket and a in-lbs or ft-lbs torque wrench, turn the 1-1/8" hex of the Collet Shank in a clockwise direction until tight and the specified torque is reached.

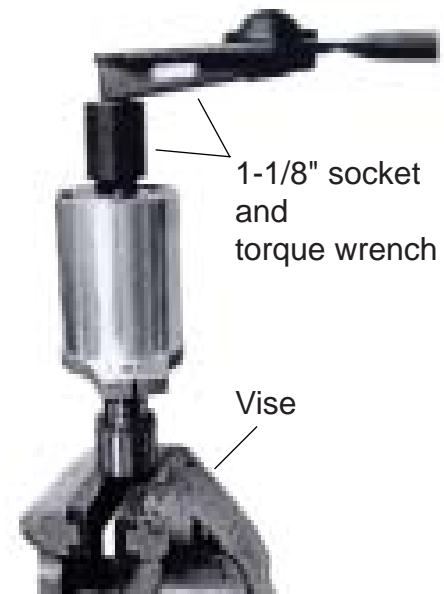

The reverse is an optional method:
Clamp the 1-1/8" hex of the Collet Shank in a vise.
Use an 11/16" hex socket and torque wrench on the 11/16" hex of the '3 Jaw Chuck' service tool to tighten the assembly to specification.

45-10-0081 Collet Shank – removal / installation

(For tools with armatures shafts that do have a 3/8" internal hex)

Removal of the Collet Shank from the Armature shaft...

Note: The Armature shaft has a 3/8" internal hex; The Collet Shank threads onto the Armature shaft.

Step 1 applied at the time of assembly, mild heat to the Collet Shank will soften Loctite® Threadlocker and will aide in the disassembly. Care should be taken with a heat gun, not to damage the seal of the Ball Bearing or Contamination Shield.

Step 2 to hold the Armature **securely from turning**, pass a 3/8" t-handle Hex Key through the Collet Shank and into the Armature's 3/8" internal hex.



3/8" t-handle
Hex Key

Step 3 using the Router's standard equipment Forged 1-1/8" Open End Wrench on the external hex of the Collet Shank, turn the Collet Shank counter-clockwise ⤿ to remove.

Installation of the Collet Shank to the Armature shaft... torque specification of the Collet shank to the Armature shaft is **16.5 ft-lbs** [*vigorously hand-tight*]...

Installation of the Collet Shank [45-10-0081] for a 5616-20/5616-29 Body Grip Router can best be accomplished by using a 3/8" t-handle Hex Key, a 1-1/8" Crowfoot Wrench and a Torque Wrench.

Step 1 apply two drops of Loctite® 'Blue' 242® or 243 Oil Tolerant, Threadlocker or equivalent, 180° apart, to threads of the Armature shaft before threading the Collect Shank onto the Armature... care should be taken not to get tread locking sealant on the ball bearing journal of the Armature shaft.

Step 2 pass a 3/8" t-handle Hex Key through the Collect Shank and into the Armature's 3/8" internal hex to hold the Armature securely from turning.

Step 3 using a 1-1/8" Crowfoot Wrench and a Torque Wrench combination turn the 1-1/8" hex of the Collet Shank in a clockwise ⤿ direction until tight and the specified minimum of **16.5 ft-lbs** of torque is reached.



1-1/8"
Crowfoot Wrench

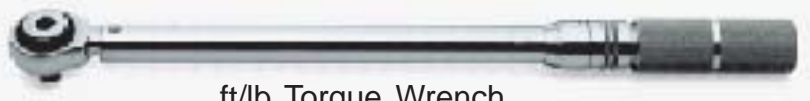

ft/lb Torque Wrench