

**RIDGID  
R2200 ROUTER  
REPAIR SHEET**

**FEUILLE DE RÉPARATION  
DE TOUPIE  
RIDGID R2200**

**RIDGID  
FRESADORA R2200  
LISTA DE PIEZAS DE REPUESTO**



# Fixed Base Assembly/Ensemble de Base Fixe/Conjunto de la Base Fija

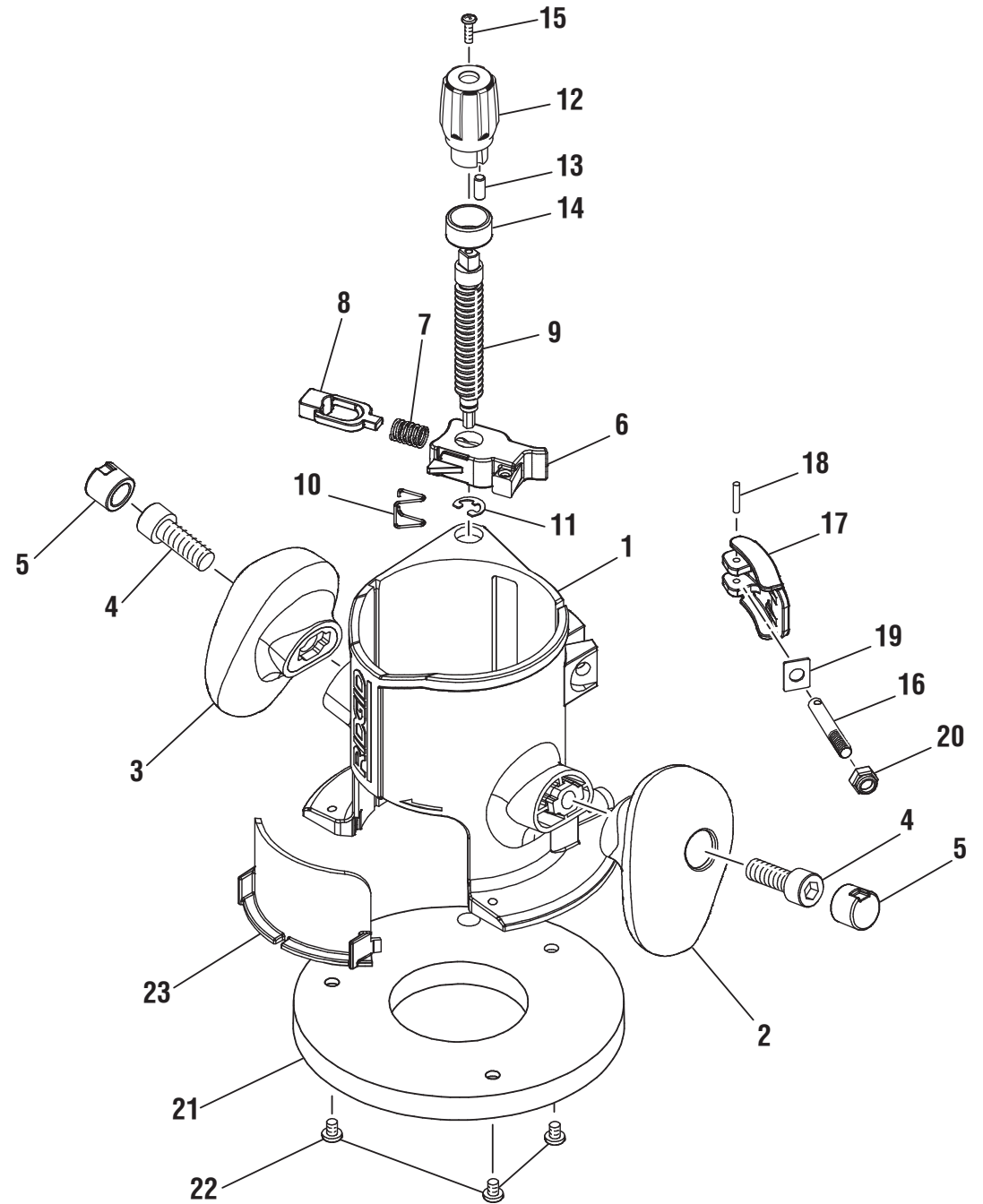
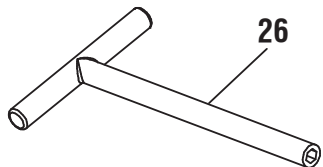
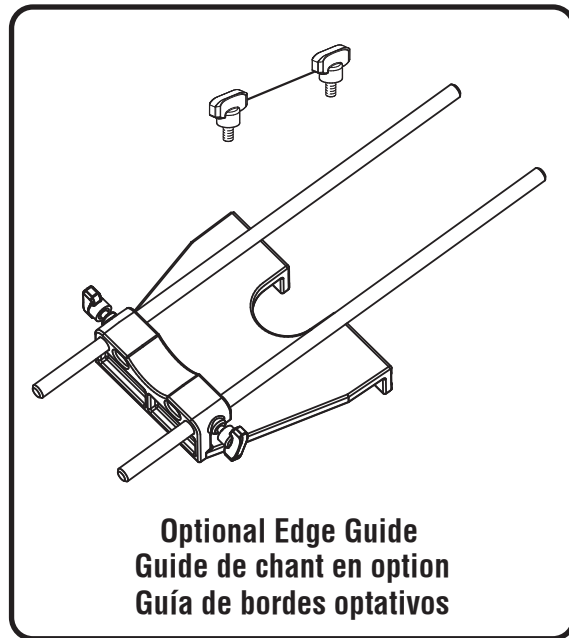
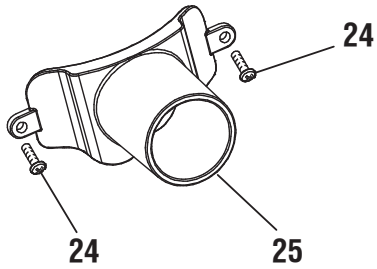



# Fixed Base Assembly/Ensemble de Base Fixe/Conjunto de la Base Fija

KEY	P/N	DESCRIPTION	QTY	PIÈCE RÉF.	DESCRIPTION	QTÉ	REF.	N/P	DESCRIPCIÓN	CANT.
1	640925001	Router Base .....	1	640925001	Base de toupie.....	1	1	640925001	Base de la fresadora.....	1
2	513347001	Right Handle Assembly.....	1	513347001	Ensemble de poignée droite.....	1	2	513347001	Conjunto de mango derecho.....	1
3	513348001	Left Handle Assembly.....	1	513348001	Ensemble de poignée gauche.....	1	3	513348001	Conjunto de mango izquierdo.....	1
4	660053003	Bolt (M10 x 28 mm, Soc. Hd.).....	2	660053003	Boulon (M10 x 28 mm, à tête creuse).....	2	4	660053003	Perno (M10 x 28 mm, cab. hueca).....	2
5	513395001	Handle Plug.....	2				5	513395001	Tapón del mango.....	2
6	640963002	Depth Interlock Lever.....	1	513395001	Bouchon de poignée.....	2	6	640963002	Palanca corta corriente de profundidad...	1
7	671758001	Compression Spring.....	1	640963002	Levier de verrouillage de la profondeur ..	1	7	671758001	Resorte de compresión.....	1
8	513396001	Depth Interlock Lever Tab (Locking Tab).....	1	7 671758001	Ressort de compression.....	1	8	513396001	Orejetas de palanca corta corriente de profundidad (orejetas de fijación).....	1
9	671757001	Height Adjustment Screw.....	1	8 513396001	Languettes de levier de verrouillage de la profondeur (languette de verrouillage)...	1	9	671757001	Tornillo de ajuste de altura.....	1
10	671759001	Torsion Spring.....	1	9 671757001	Vis de réglage de hauteur.....	1	10	671759001	Resorte de torsión.....	1
11	671797002	E-Ring.....	1	10 671759001	Ressort de torsion.....	1	11	671797002	Anillo en "e".....	1
12	513093001	Depth Adjustment Knob.....	1	11 671797002	Clip en e.....	1	12	513093001	Perilla de ajuste la profundidad.....	1
13	570334001	Rubber Plug.....	1	12 513093001	Bouton de réglage de profondeur.....	1	13	570334001	Tapón de caucho.....	1
14	340092001	Zero Reset Ring.....	1	13 570334001	Bouchon en caoutchouc.....	1	14	340092001	Anillo de ajuste a cero.....	1
15	660320008	Screw (M3.5 x 12 mm).....	1	14 340092001	Bague de remise à zéro.....	1	15	660320008	Tornillo (M3,5 x 12 mm).....	1
16	671260002	Lever Pin.....	1	15 660320008	Vis (M3,5 x 12 mm).....	1	16	671260002	Pasador de la palanca.....	1
17	201391001	Lock Lever Assembly (Inc. Key Nos. 16 and 18).....	1	16 671260002	Goupille du levier.....	1	17	201391001	Conjunto de pasador de la palanca (inc. pzas. núms. ref. 16 y 18).....	1
18	671247001	Needle Roller Pin.....	1	17 201391001	Ensemble de axe de levier (inc. pièces no. 16 et 18).....	1	18	671247001	Pasador de articulación de la aguja.....	1
19	631421001	Wear Plate.....	1	18 671247001	Goupille cylindrique d'aiguilles.....	1	19	631421001	Placa de rozamiento.....	1
20	671243003	Lock Nut (Hex).....	1	19 631421001	Plaque d'usure.....	1	20	671243003	Tuerca de seguridad (hex.).....	1
21	513087001	Subbase.....	1	20 671243003	Écrou de blocage (hex.).....	1	21	513087001	Subbase.....	1
22	660136003	Screw (10-32 x 3/8 in.).....	3	21 513087001	Semelle.....	1	22	660136003	Tornillo (10-32 x 3/8 pulg.).....	3
23	513094001	Chip Shield.....	1	22 660136003	Vis (10-32 x 3/8 po).....	3	23	513094001	Protector contra virutas.....	1
24	660284010	Screw (#6-32 x 3/8 in., Pan Hd.).....	2	23 513094001	Pare-copeaux.....	1	24	660284010	Tornillo (#6-32 x 3/8 pulg., cab. troncocónica).....	2
25	513349001	1-1/4 in. Vacuum Adapter.....	1	24 660284010	Vis (#6-32 x 3/8 po, tête bombée).....	2	25	513349001	1-1/4 pulg. colector de polvo.....	1
26	513667001	T-Handle Wrench.....	1	25 513349001	1-1/4 po collecteur de poussière.....	1	26	513667001	Llave de mango en "t".....	1
27	300869006	Optional Edge Guide.....	1	26 513667001	Clé en t.....	1	27	300869006	Guía de bordes optativos.....	1
	<b>Not Shown:</b>				<b>Pas illustré :</b>			<b>No se ilustra:</b>		
	660235013	Screw (10-32 x 12 mm, Router Table Attachment Screws).....	3	660235013	Vis (10-32 x 12 mm, vis de fixation de table à toupie).....	3		660235013	Tornillo (10-32 x 12 mm, tornillos del aditamento de mesa para fresadora).....	3

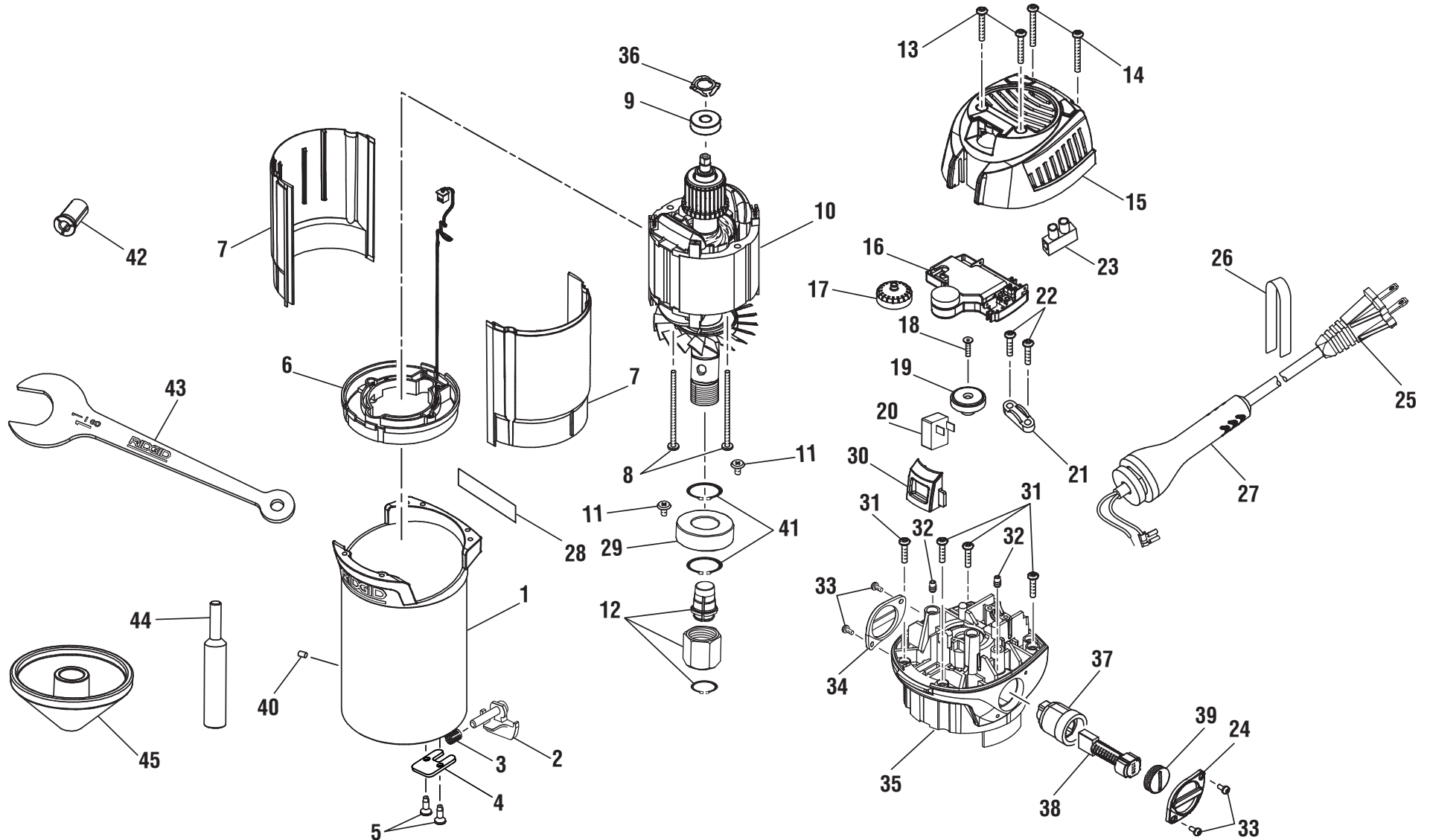

**▲ WARNING:** The assembly shown represents an important part of the Double Insulated System. To avoid the possibility of alteration or damage to the System, service should be performed by your nearest authorized service center.

**▲ AVERTISSEMENT :** L'ensemble illustré représente une partie importante du système à isolation double. Afin d'éviter la possibilité de modification ou de dommage au système, la réparation ne doit être effectuée que par votre centre de réparation centre commercial autorisé.

**▲ ADVERTENCIA:** El conjunto que se ilustra representa una parte importante del Sistema de Aislamiento Doble. Para evitar la posibilidad de alteración o daño del sistema, la reparación debe ser efectuada en su centro de servicio autorizado.



# Motor Assembly

KEY	P/N	DESCRIPTION	QTY
1	201387001	Motor Housing Assembly	1
	641375001	Motor Housing	1
2	515210002	Shaft Lock Button	1
3	690141003	Shaft Lock Spring	1
4	631966002	Cover Plate	1
5	661039001	Screw (#8-32 x 3/8 in.)	2
6	290139020	LED Assembly	1
7	519267001	Insulating Sleeve	2
8	660237009	Screw (11/64 x 2-5/8 in.)	2
9	680966001	Ball Bearing (NTN #608LLUC3/1E)	1
10	290332001	Motor Assembly (Incl. Key Nos. 9, 29 and 41)	1
11	660324002	Screw (#10-32 x 3/8 in., Wafer Hd.)	2
12	201389001	Collet Assembly (1/2 in.)	1
13	660436006	Screw (M4 x 25 mm, Pan Hd.)	2
14	660437004	Screw (M4 x 32 mm, Pan Hd.)	2
15	340084002	Top Cap	1
16	280013219	Circuit Board Assembly	1
17	340338001	Variable Speed Dial	1
18	660423005	Screw (M3.5 x 14 mm)	1
19	301303001	Magnet	1
20	760385003	Slide Switch	1
21	590924001	Cord Clamp	1
22	660372001	Screw (#6-19 x 16 mm, T15 Torx Pan Hd.)	2
23	690331004	Terminal Block	1
24	513400001	Brush Cap Retainer (Right Hand)	1

KEY	P/N	DESCRIPTION	QTY
25	201390001	Power Cord Assembly (Incl. Key Nos. 26-27)	1
26	940299942	Cord Tag	1
27	561365001	Bend Relief	1
28	940976444	Data Label	1
29	680733001	Ball Bearing (6004W)	1
30	513086002	Switch Actuator	1
31	660212053	Screw (M4 x 16 mm)	4
32	660067001	Screw (#8-16 x 1/4 in.)	2
33	660438002	Screw (M3 x 8 mm, Pan Hd.)	4
34	513397001	Brush Cap Retainer (Left Hand)	1
35	519273001	Bearing Bracket w/Insert	1
36	671862002	Loading Spring	1
37	301035001	Brush Holder Assembly	2
38	301036001	Brush Assembly	2
39	512010001	Brush Cap	2
40	671881001	Pin	1
41	680370001	Retaining Ring	2
42	672036001	Collet Adaptor (1/4 in.)	1
43	670346004	Wrench	1
44	671675001	Centering Tool (Pin/Shaft)	1
45	513095001	Centering Tool (Cone)	1

**Not Shown:**

901311004	Tool Bag	1
988000474	Operator's Manual	1
3-31-11 (Rev:01)		



# Ensemble de Moteur

PIÈCE	RÉF.	DESCRIPTION	QTÉ	PIÈCE	RÉF.	DESCRIPTION	QTÉ
1	201387001	Ensemble de boîtier du moteur .....	1	25	201390001	Cordon d'alimentation (inc. pièces no. 26-27).....	1
	641375001	Boîtier du moteur .....	1	26	940299942	L'étiquette du cordon.....	1
2	515210002	Goupille de verrouillage d'axe .....	1	27	561365001	Protecteur de cordon.....	1
3	690141003	Ressort de verrouillage d'axe .....	1	28	940976444	Étiquette de données.....	1
4	631966002	Couvercle.....	1	29	680733001	Roulement (6004W) .....	1
5	661039001	Vis (#8-32 x 3/8 po).....	2	30	513086002	Actionneur de commutateur .....	1
6	290139020	Ensemble de DÉL .....	1	31	660212053	Vis (M4 x 16 mm) .....	4
7	519267001	Manchon isolant .....	2	32	660067001	Vis (#8-16 x 1/4 po).....	2
8	660237009	Vis (11/64 po x 2-5/8 po) .....	2	33	660438002	Vis (M3 x 8 mm, tête bombée).....	4
9	680966001	Roulement (NTN #608LLUC3/1E) .....	1	34	513397001	Retenue de capuchon de balai (main gauche) .....	1
10	290332001	Ensemble de moteur (inc. pièces no. 9, 29 et 41) .....	1	35	519273001	Support de roulement avec insert .....	1
11	660324002	Vis (#10-32 x 3/8 po, à tête mince).....	2	36	671862002	Ressort de charge.....	1
12	201389001	Collet (1/2 po) .....	1	37	301035001	Ensemble de porte-balai.....	2
13	660436006	Vis (M4 x 25 mm, à tête bombée).....	2	38	301036001	Ensemble de balai .....	2
14	660437004	Vis (M4 x 32 mm, à tête bombée).....	2	39	512010001	Capuchon de balai.....	2
15	340084002	Couvercle supérieur.....	1	40	671881001	Goupille.....	1
16	280013219	Carte de circuit imprimé .....	1	41	680370001	Bague de retenue .....	2
17	340338001	Sélecteur de vitesse variable .....	1	42	670344002	Adaptateur de collet (1/4 po) .....	1
18	660423005	Vis (M3,5 x 14 mm) .....	1	43	670346004	Clé.....	1
19	301303001	Almant.....	1	44	671675001	Outil de centrage (goupille / arbre) .....	1
20	760385003	Communtateur à glissière.....	1	45	513095001	Outil de centrage (cône) .....	1
21	590924001	Retenue de cordon .....	1	<b>Pas illustré :</b>			
22	660372001	Vis (#6-19 x 16 mm, T15 Torx tête bombée).....	2	901311004	Sacoche.....	1	
23	690331004	Plaque à bornes.....	1	988000474	Manuel d'utilisation.....	1	
24	513400001	Retenue de capuchon de balai (main droite).....	1				



## Conjunto de Motor

REF.	N/P	DESCRIPCIÓN	CANT.	REF.	N/P	DESCRIPCIÓN	CANT.
1	201387001	Conjunto del alojamiento del motor .....	1	25	201390001	Conjunto de cordón de corriente (incl. pièces no. 26-27) .....	1
	641375001	Alojamiento del motor.....	1	26	940299942	Etiqueta del cordón .....	1
2	515210002	Pasador del seguro del eje .....	1	27	561365001	Protector del cordón.....	1
3	690141003	Resorte del seguro del eje.....	1	28	940976444	Etiqueta de datos.....	1
4	631966002	Placa tapadora.....	1	29	680733001	Cojinete de bolas (6004W).....	1
5	661039001	Tornillo (#8-32 x 3/8 pulg.).....	2	30	513086002	Accionador del interruptor.....	1
6	290139020	Conjunto de diodo luminiscente .....	1	31	660212053	Tornillo (M4 x 16 mm) .....	4
7	519267001	Camisa aislante .....	2	32	660067001	Tornillo (#8-16 x 1/4 pulg.).....	2
8	660237009	Tornillo (11/64 pulg. x 2-5/8 pulg.).....	2	33	660438002	Tornillo (M3 x 8 mm, cab. trunc.) .....	4
9	680966001	Cojinete de bolas (NTN #608LLUC3/1E) .....	1	34	513397001	Retén de la tapa de la escobilla (mano izquierda).....	1
10	290332001	Conjunto del motor (incl. pièces no. 9, 29 y 41).....	1	35	519273001	Soporte del cojinete con inserte.....	1
11	660324002	Tornillo (#10-32 x 3/8 pulg., cabeza de galleta).....	2	36	671862002	Resorte de carga .....	1
12	201389001	Conjunto del casquillo (1/2 pulg.).....	1	37	301035001	Conjunto del portaescobilla.....	2
13	660436006	Tornillo (M4 x 25 mm, cab. trunc.) .....	2	38	301036001	Conjunto de la escobilla .....	2
14	660437004	Tornillo (M4 x 32 mm, cab. trunc.).....	2	39	512010001	Tapa de la escobilla .....	2
15	340084002	Tapa superior .....	1	40	671881001	Pasador.....	1
16	280013219	Conjunto de la placa de circuitos .....	1	41	680370001	Aro de retén .....	2
17	340338001	Selector giratorio de velocidad.....	1	42	670344002	Adaptador del portaherramientas (1/4 pulg.).....	1
18	660423005	Tornillo (M3,5 x 14 mm) .....	1	43	670346004	Llave .....	1
19	301303001	Imán .....	1	44	671675001	Centrador (pasador).....	1
20	760385003	Deslice el interruptor.....	1	45	513095001	Centrador (cono).....	1
21	590924001	Abrazadera del cordón .....	1			<b>No se ilustra:</b>	
22	660372001	Tornillo (#6-19 x 16 mm, T15 Torx cab. trunc.).....	2	901311004	Bolsa de herramientas .....	1	
23	690331004	Bloque de terminales.....	1	988000474	Manual del operador.....	1	
24	513400001	Retén de la tapa de la escobilla (mano derecha).....	1				

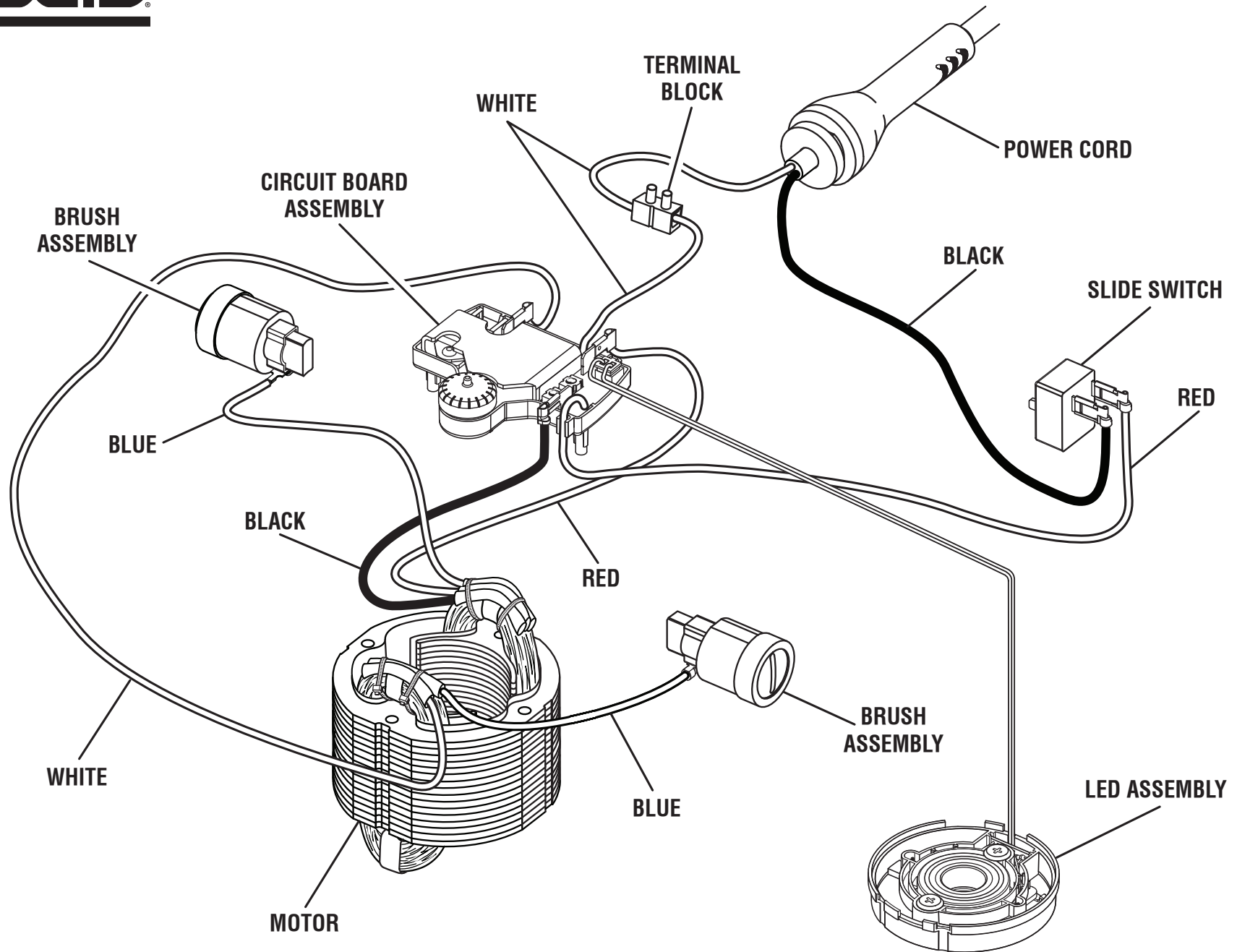

Wiring Diagram / Schéma de câblage / Diagrama de cableado